

# TRUMBULL

1040 N. Meridian Rd., P.O. Box 1556, Youngstown, Ohio 44501  
 Phone: 330.799.3333 • Toll Free: 800.677.1799 • FAX: 330.797.3215

[www.trumbull-mfg.com](http://www.trumbull-mfg.com)

## DISTANCE MEASURING WHEEL

*Includes Storage Bag*

TRUMBULL'S HEAVY-DUTY DISTANCE MEASURING WHEEL is ideal for laying out and measuring utility lines, road work, and other types of construction. Lightweight design makes it easy to use, reducing fatigue. Folding handle design requires minimal storage space and fits conveniently inside padded storage bag.

Internal axle bearings provide for long life under a wide variety of applications. Six figure counter records long distances up to 100,000 ft. over most types of terrain. Large counter makes reading measurements easy. Hand-grip brake eliminates unwanted measurement at turns or when maneuvering around objects not to be measured.

Handle, front forks, and kickstand are coated carbon steel. Wheel rim and hand grip brake made of ABS. Tire is made of 90-Durometer Black PVC.

<u>Trumbull Item No.</u>	<u>Measurement</u>	<u>Color</u>
217-1235	Feet	Green
217-1236	Meters	Red

Wheel Diameter: 12-1/2"  
 Extended Length: 3'8"  
 Weight of Measuring Wheel: 5 lbs.  
 Weight of Carrying Bag: 1 lb.  
 Weight of Wheel with Bag: 6 lbs.

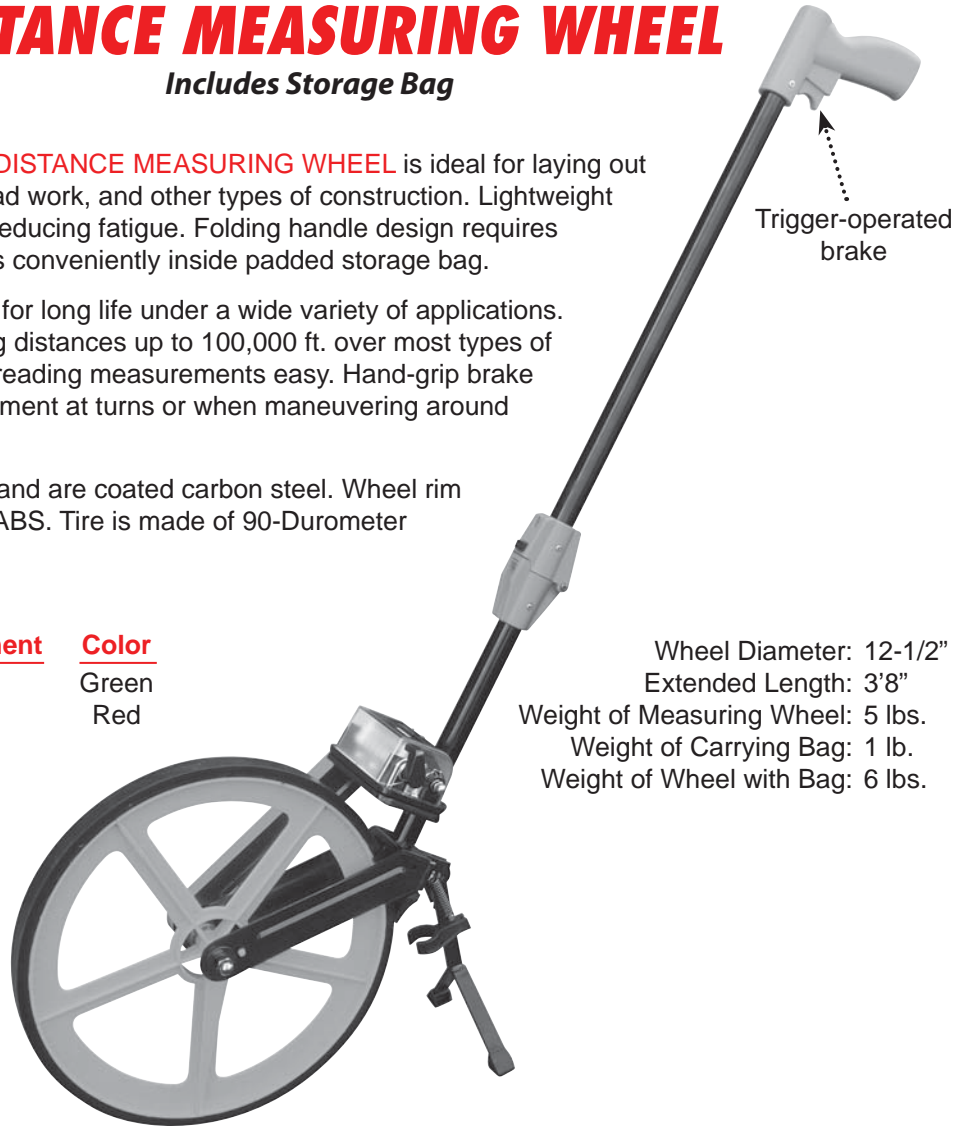

Trigger-operated brake

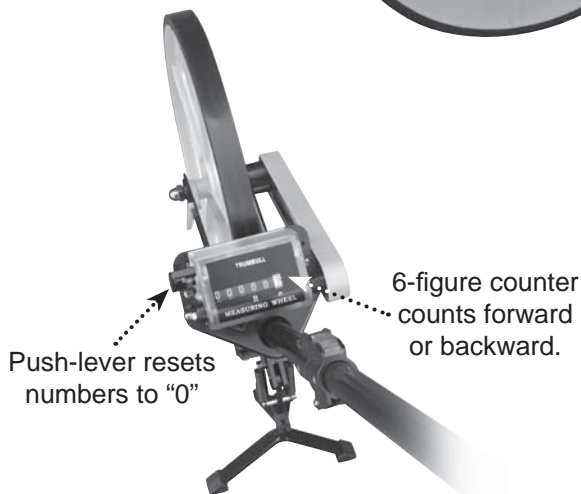

Push-lever resets numbers to "0"

6-figure counter counts forward or backward.



Folding-handle design fits neatly inside storage bag.