

TRUMBULL

1040 N. Meridian Rd., P.O. Box 1556, Youngstown, Ohio 44501
 Phone: 330.799.3333 • Toll Free: 800.677.1799 • FAX: 330.797.3215

www.trumbull-mfg.com

30" DUCTILE INDICATING FLOORSTAND

TRUMBULL 30" INDICATING FLOORSTANDS are designed for installation in treatment plants and pump stations to allow operation of valves at a lower elevation. Floorstand body is ductile iron for increased torque capacity. Stainless steel Floorstands available, please inquire. Our standard Floorstand is shown below; special mountings & stems are available. See reverse side for drawing of Floorstand & optional Floorstand Bracket.

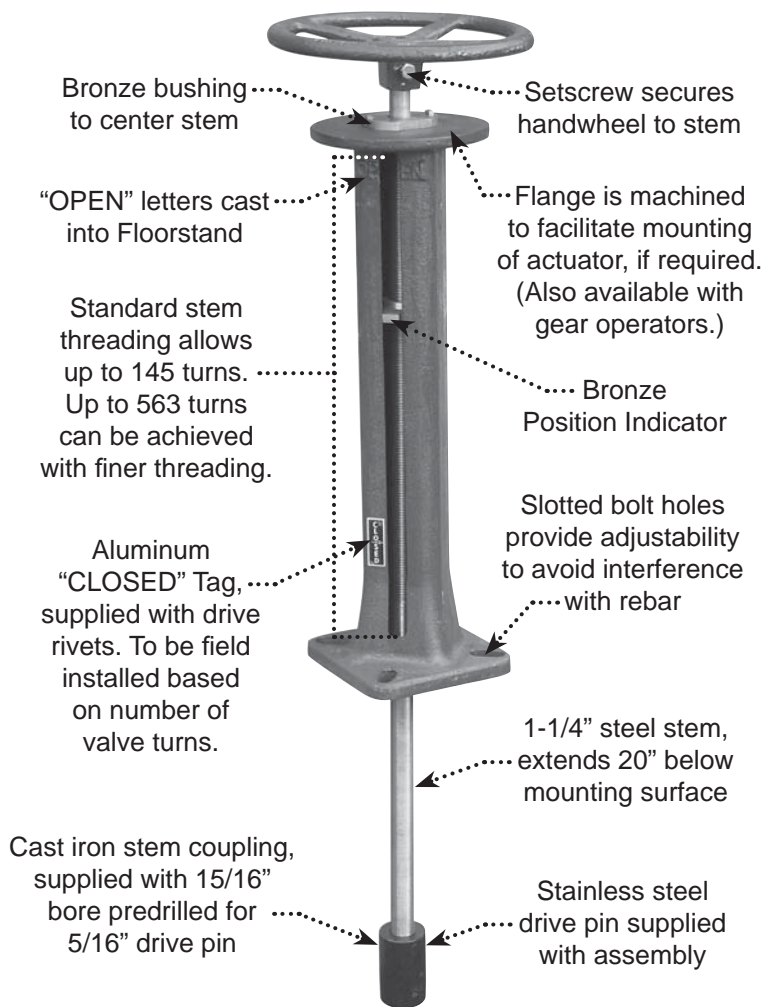

ORDERING INFORMATION:

1. Quantity.
2. Trumbull item number (367-2420)
3. O.D. of extension stem being used, for drilling of connecting couplings.

See separate literature on Trumbull Floor Boxes, Extension Stems, Stem Guides, Mud Valves and 36" ductile or stainless Indicating Floorstands with Lexan window.

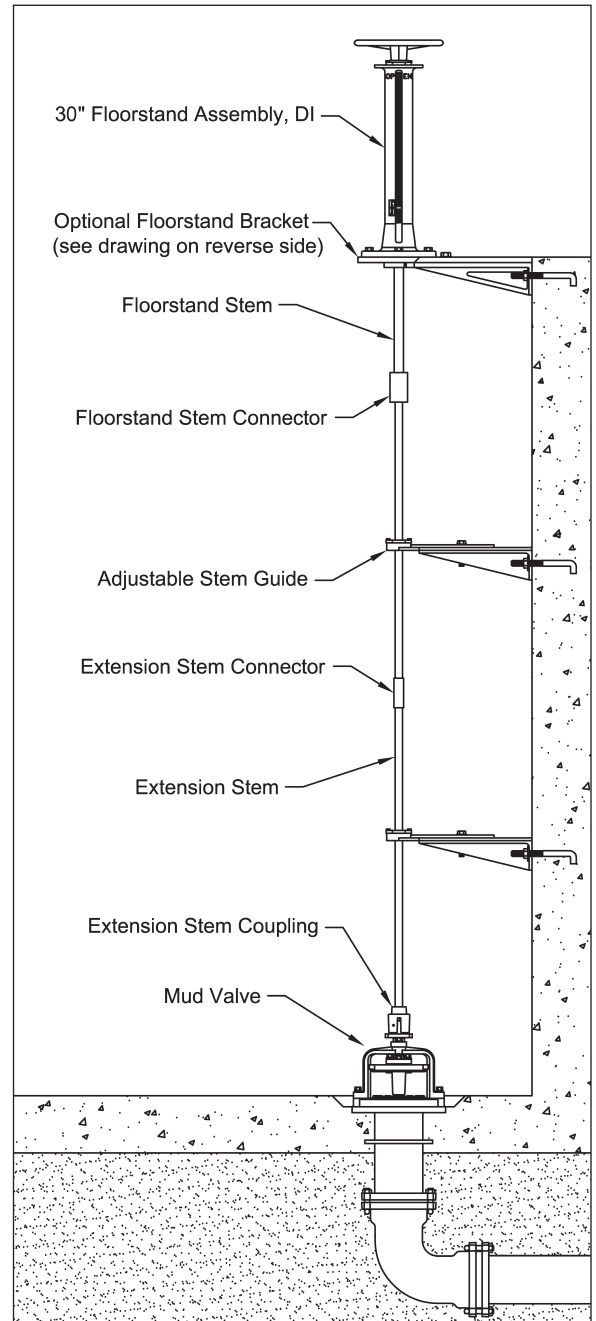

Typical Floorstand installation