

Item	Part	Material
1	Base	Ductile Iron or Stainless Steel
2	Arm	Ductile Iron or Stainless Steel
3	Clamp	Ductile Iron or Stainless Steel
4	Bushing	UNS C86400 (B584) Manganese Bronze
5	Bolt	5/8" x 4", Hex Head, Stainless Steel
6	Washer	1-1/2" O.D., Stainless Steel
7	Nut	5/8", Hex, Stainless Steel
8	Screw	1/4"-20 U.N.C., Stainless Steel

Item No.	Size	Weight
Ductile Iron Guides (65-45-12)		
367-4960	2"-26"	25#
367-4970	2"-36"	28#
Stainless Steel Guides (T316)		
367-5960	2"-26"	28#
367-5970	2"-36"	32#

All Ductile Iron components are coated with NSF 61 paint

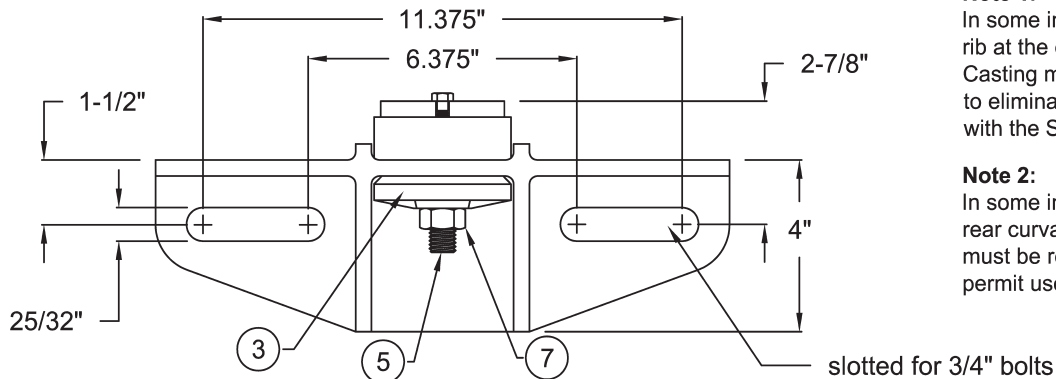
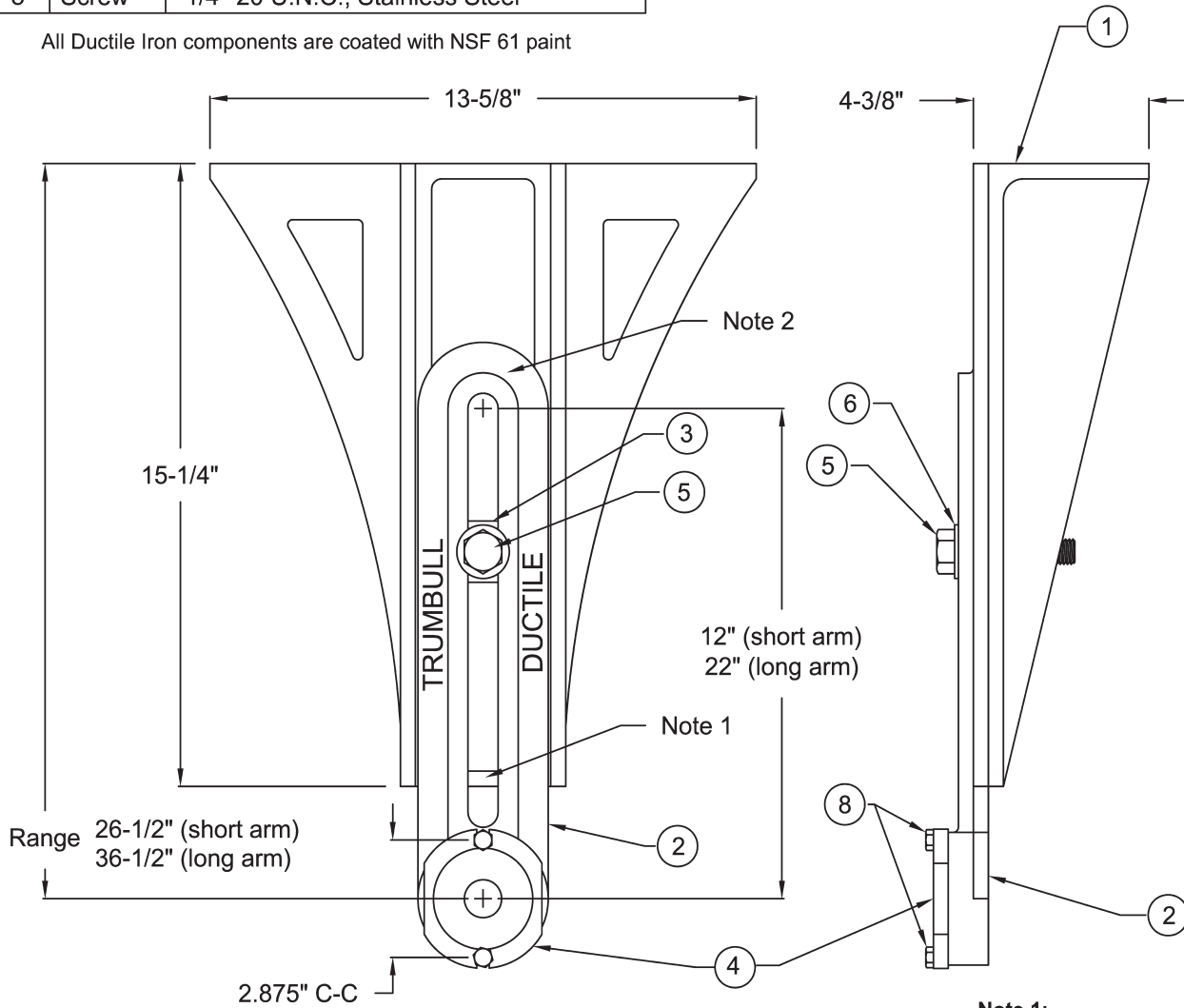

Note 1:
In some installations the rib at the end of the Base Casting must be removed to eliminate interference with the Stem.

Note 2:
In some installations the rear curvature of the Arm must be removed to permit use of short arm.

Drawn:	Drawing Revision:	
Date	Rev.	Date
4/4/94	J	4/16/08

TRUMBULL INDUSTRIES
P.O. Box 1556
1040 N. Meridian Rd.
Youngstown, Ohio 44501

Drawn to Scale
ADJUSTABLE STEM GUIDES