

ADJUSTABLE STEM GUIDE for Large Diameter Stems

TRUMBULL STEM GUIDES are designed as wall brackets for installation in treatment plants and pump stations to provide support for valve extension stems.

This ductile iron Stem Guide accommodates larger stem diameters, expanding the bore capacity of our Adjustable Stem Guide product line. Furnished with a split bronze bushing to fit stem sizes from 2" to 4" outside diameters. The adjustment range will allow stem centerlines as close to the wall as 2-3/4", or as far as 17-1/4".

Stem guides are generally recommended at 10 feet intervals.

<u>Trumbull Item No.</u>	<u>Adjustment</u>	<u>Weight</u>
367-6960	2-3/4" - 17-1/4"	40.0 lbs.

..... End Cap design provides a safety restraint for large or unwieldy stems during installation or maintenance.

..... Split bushing simplifies the installation of large extension stems.

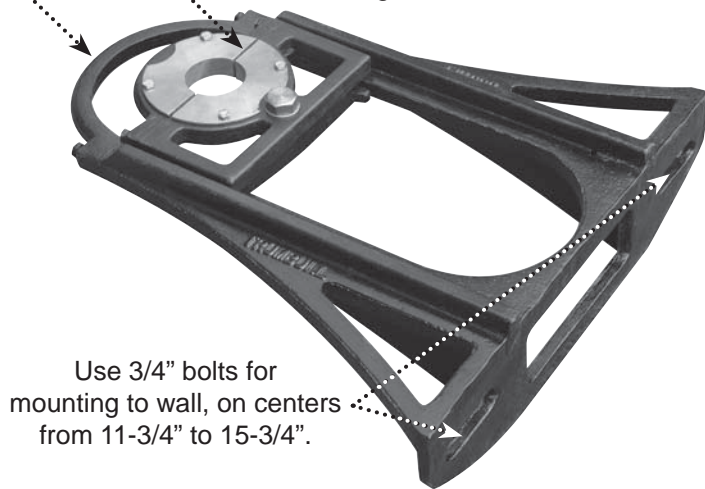

Use 3/4" bolts for mounting to wall, on centers from 11-3/4" to 15-3/4".

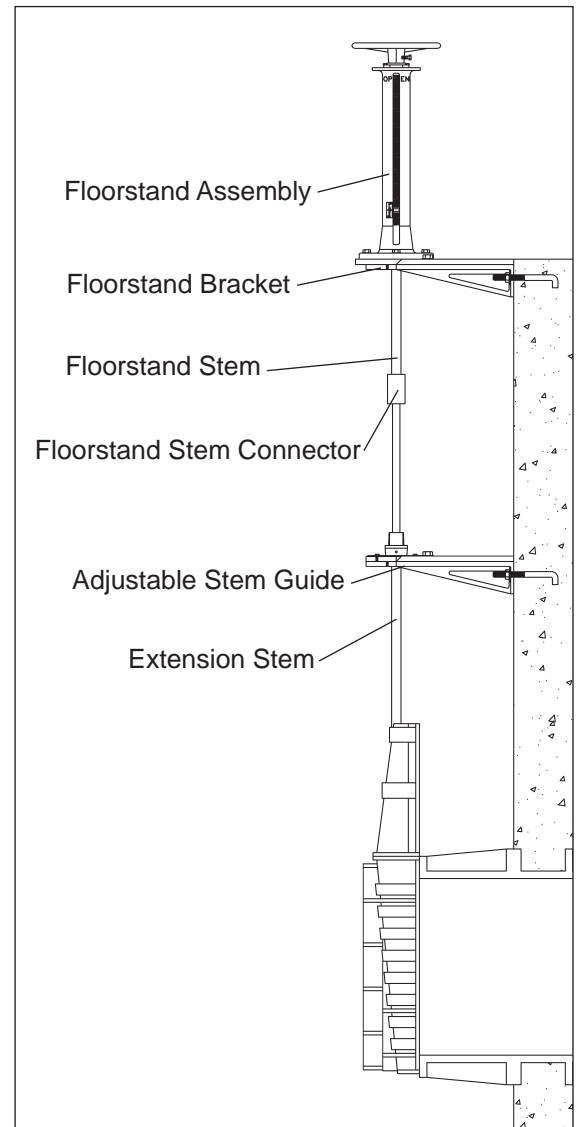

Typical Stem Guide installation

Stem Guides are also available in Stainless Steel; please inquire.

ORDERING INFORMATION:

1. Quantity.
2. Trumbull item number (367-6960)
3. O.D. of stem being used, or desired bushing hole size (2-1/8" bore diameter supplied if not specified.)

See separate literature on Trumbull Floorstands, Floor Boxes, Extension Stems, Stem Guides and Mud Valves.

See reverse side for drawing.