

Larger Diameter Adjustable Stem Guides

Removable End Cap Design

Trumbull Larger Diameter Stem Guides are designed for installation in treatment plants and pump stations to provide support for valve extension stems. They accommodate larger stem diameters, expanding the bore capacity up to 4". Coated with Tnemec N140-1211 epoxy (complies with NSF 61). See reverse side for drawing.

Stem Guides are generally recommended at 6' to 8' intervals.

END CAP DESIGN
provides a safety restraint for large or unwieldy stems during installation or maintenance

SPLIT BUSHINGS
simplify the installation of larger diameter extension stems

USE 3/4" ANCHORS
for mounting to wall, on centers from 11-3/4" to 15-3/4", supplied by others

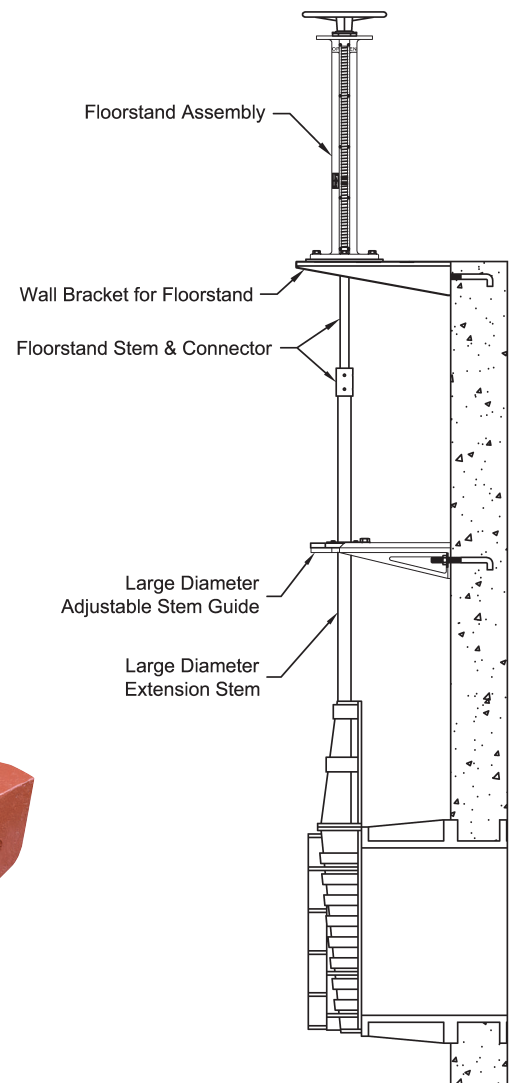
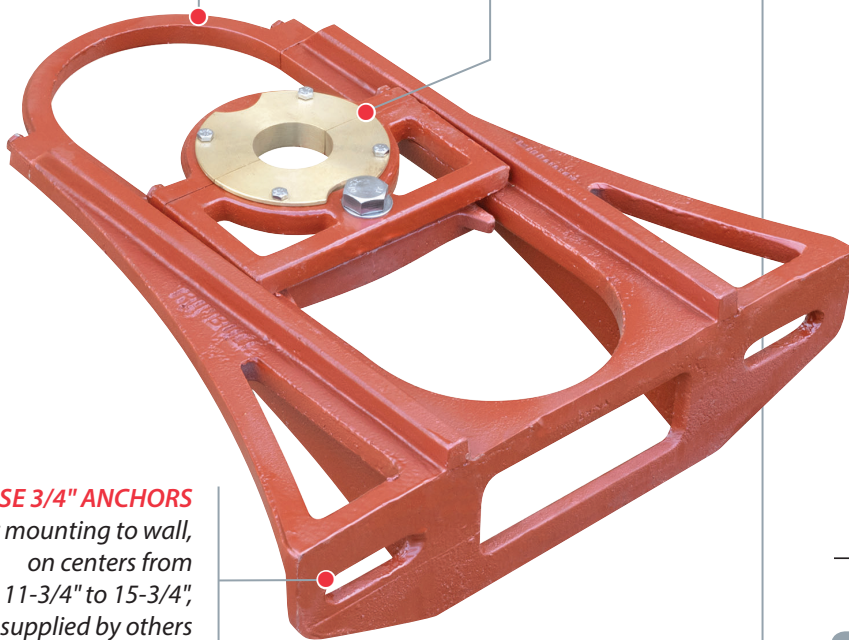

Typical installation

Trumbull Item No.	Adjustment Range	For Stem Diameters	Weight
367-6960	2-3/4" to 17-1/4" *	2" to 4"	38.65 lbs.

* Adjustment range dependent on stem diameter

Stem Guides for 4" to 6-1/2" stem diameters, as well as stainless steel models without end caps are shown on pages G-23 and G-24.

Ordering Instructions

1. Quantity required
2. Trumbull item number
3. O.D. of stem being used, or desired bushing material & hole size

Note that a 2-1/8" bore diameter bushing supplied if size is not specified.

Item	Part	Material
1	Base	Ductile Iron
2	Arm	Ductile Iron
3	Clamp	Ductile Iron
4	Bushing	Bronze
5	Bolt	5/8" x 4", Hex Head, Stainless Steel
6	Washer	1-1/2" O.D., Stainless Steel
7	Screw	1/4"-20 U.N.C., Stainless Steel

All ductile iron components are coated with Tnemec 140-1211, NSF 61 compliant.

Weight of assembly: 43#

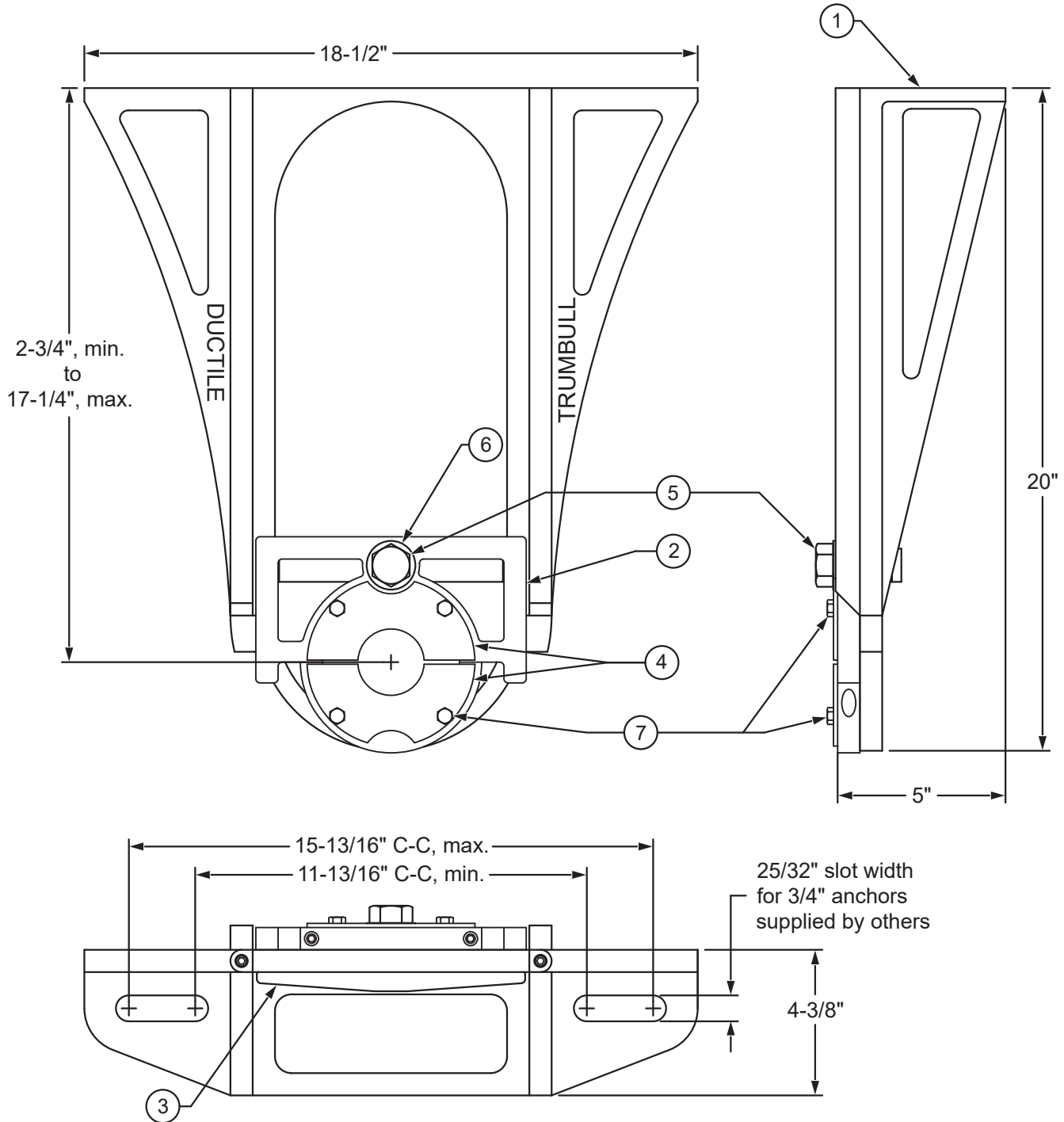

LARGE BORE STEM GUIDE

Drawn to Scale

Drawn:
FCN
08/23/99

Revision:
FCN
04/07/15

Trumbull Manufacturing, Inc.
Youngstown, Ohio
www.trumbull-mfg.com