

11-1/8" Sealed Floor Boxes

Available in Cast Carbon Steel and Cast Stainless Steel



SOCKET HEAD CAP SCREWS

furnished standard (tamper-resistant fasteners and installation tools also available)

BUNA-N O-RING

Seals Floor Box at top of floor; furnished standard, other materials available upon request

OVERALL HEIGHT

11-1/8" with lid

Trumbull Sealed Floor Boxes are ideal to prevent fluids and vapors from penetrating the floor slab from either direction. Top side is sealed by a Buna-N O-ring, and bottom side can be sealed by use of optional packing gland. Overall length is 11-1/8", but the underside is tapped to accept 2-1/2" NPT steel pipe nipples for floors thicker than 11". When it's necessary to extend a Floor Box for thicker floors, use a 2-1/2" pipe nipple, 1/2" longer than the increase required, as the threads on the underside of the Floor Box are 1/2" deep.

i Tapped 2-1/2" threads also permit threading 2-1/2" pipe into underside of Floor Box, to provide an external casing for a smaller internal extension stem.

Floor Boxes

Material	Item No	Weight
Cast Carbon Steel*	367-4622	31.05 lbs.
Cast 316 Stainless Steel	367-4621	33.45 lbs.

* Carbon steel models are EDP coated.

Optional Accessories

Available as special order

PACKING GLAND

with stainless steel follower seals bottom of Floor Box

BRASS BUSHING

aligns extension stem when bottom seal is not utilized

POSITION INDICATOR

can be used with either brass bushing or packing gland, see Pages F-7 and F-8 for Trumbull Valve Position Indicator installation in floors.

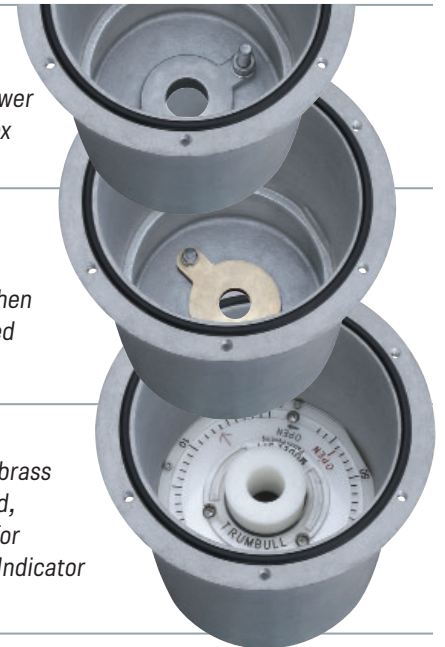

Description	Weight
SS Packing Gland	2.10 lbs.
Brass Bushing	1.75 lbs.

See Page G-13 for other custom options.

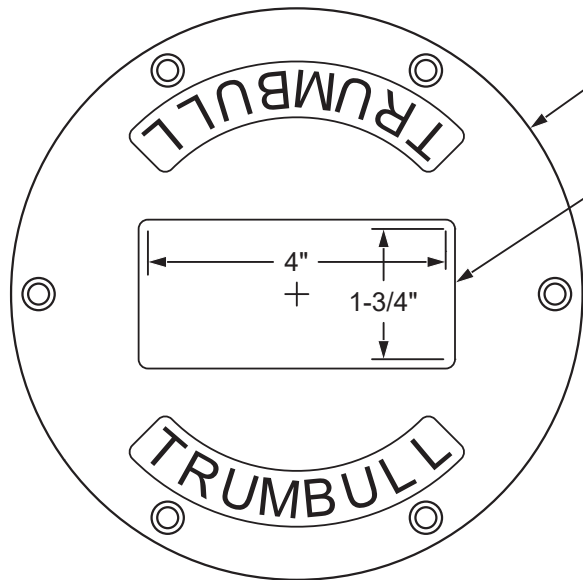

7-11/16", Lid diameter

Flat surface for custom logo;
consult Sales Rep. for details.

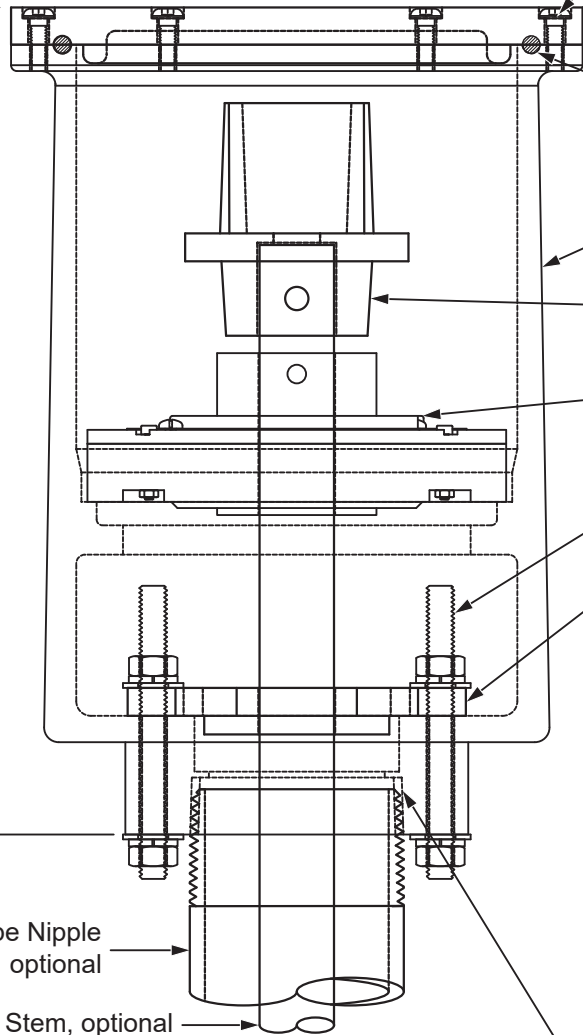
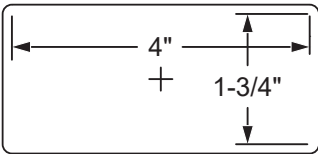

Lid Fasteners

Lid

O-Ring Lid Seal

Floor Box Canister

2" Operating Nut, optional

Position Indicator, optional

Fasteners, optional

Bushing, optional

11-1/8"
overall

Pipe Nipple
optional

Valve Stem, optional

Notes:

Canister, Lid, and fasteners are T316 stainless.
Also available in cast carbon steel.
Carbon steel model is EDP coated.
Available plain, with Bushing, or Packing Gland.
For Bushing, specify bore dia. desired.
For Packing Gland, specify Stem Dia. and type
of Packing Material required.
Pipe nipple for extending length is not furnished.
Lid O-Ring and fasteners are included.
Position Indicator is a recommended option.

The bottom of the Floor Box casting
is tapped with a 2-1/2" NPT thread.

SEALED FLOOR BOX
CAST T316SS or CS - 11" OAH
Drawn to Scale

Drawn:
FCN
05/29/14

Revision:
FCN
D 04/25/15

Trumbull Manufacturing
Youngstown, Ohio
www.trumbull-mfg.com