

30" Ductile Iron Indicating Floorstand

Trumbull 30" Indicating Floorstands are designed for installation in treatment plants and pump stations to allow operation of valves at a lower elevation. Floorstand body is ductile iron for increased torque capacity. Set screw secures handwheel to stem. Flange can be machined to facilitate mounting of actuator, if required (also available with gear operators). Our standard Floorstand is shown below (see page G-34 for custom Floorstand options). Stocked for "open left" valves; also available for "open right" valves. Standard stem threading allows up to 140 turns; optional threading allows up to 563 turns. Stainless drive pin supplied with assembly.

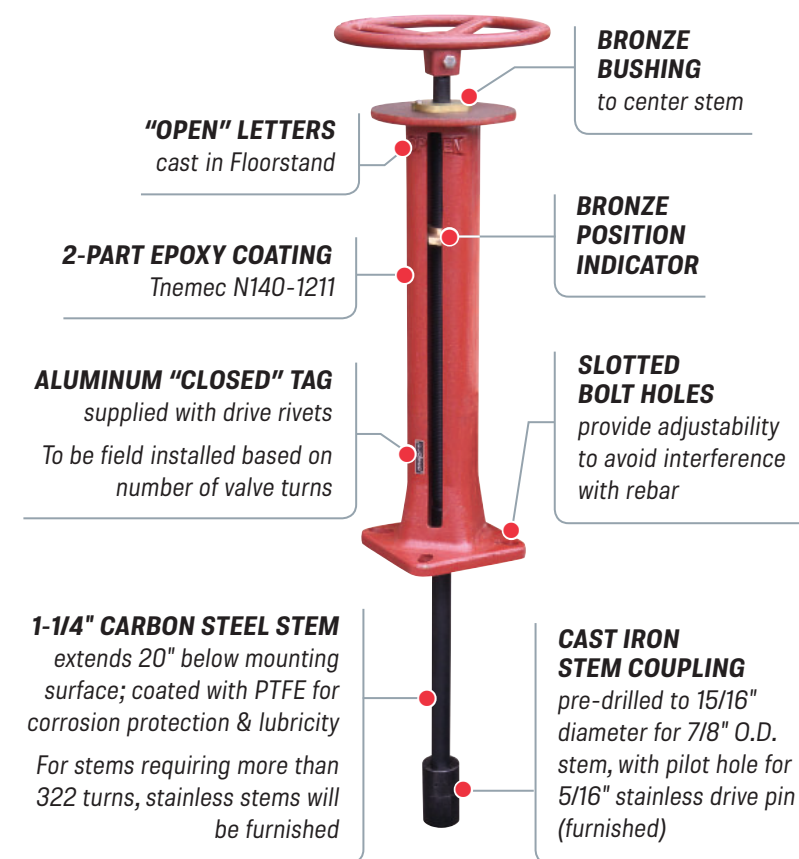

Ordering Instructions

1. Quantity required
2. Floorstand item number: **367-2420**
3. O.D. of extension stem being used, for drilling of connecting couplings
4. Wall Bracket, if required
 - a. Ductile iron item number: **367-2451**
 - b. Stainless steel item number: **367-2461**

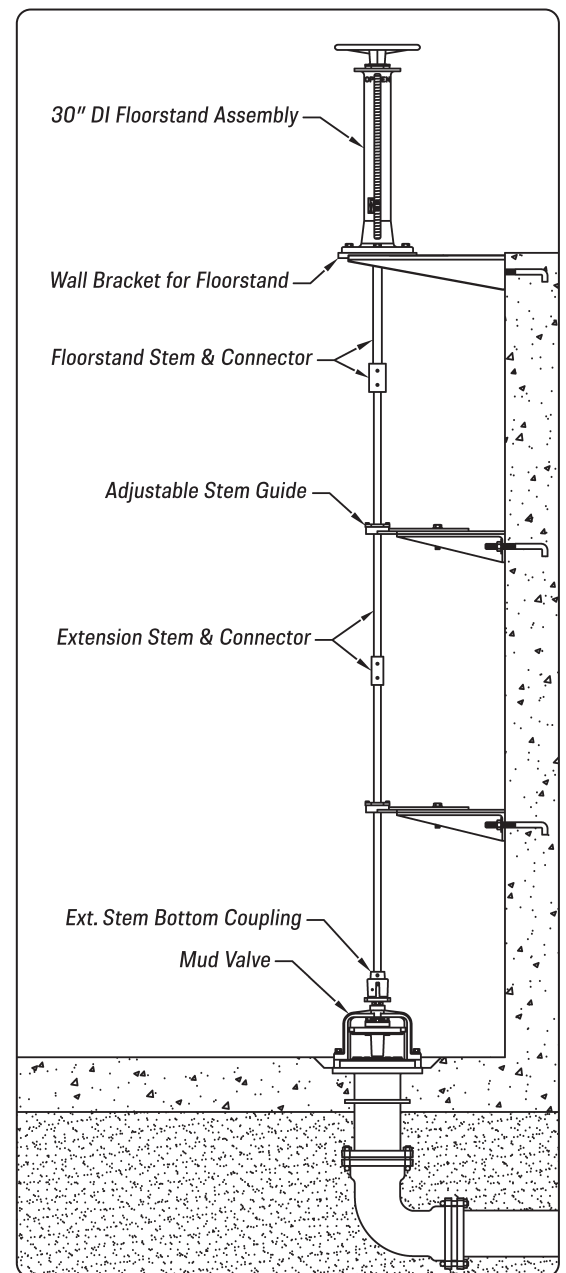

Typical Floorstand installation

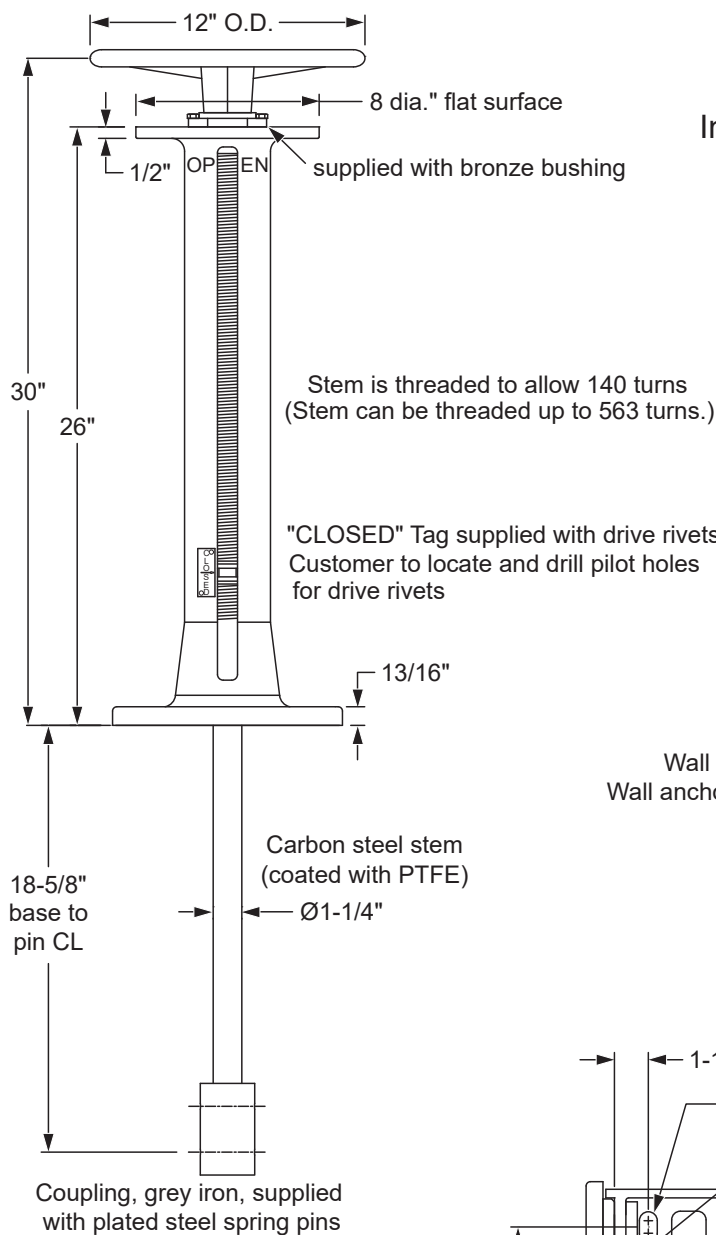

Installation of Floorstand on Wall Bracket

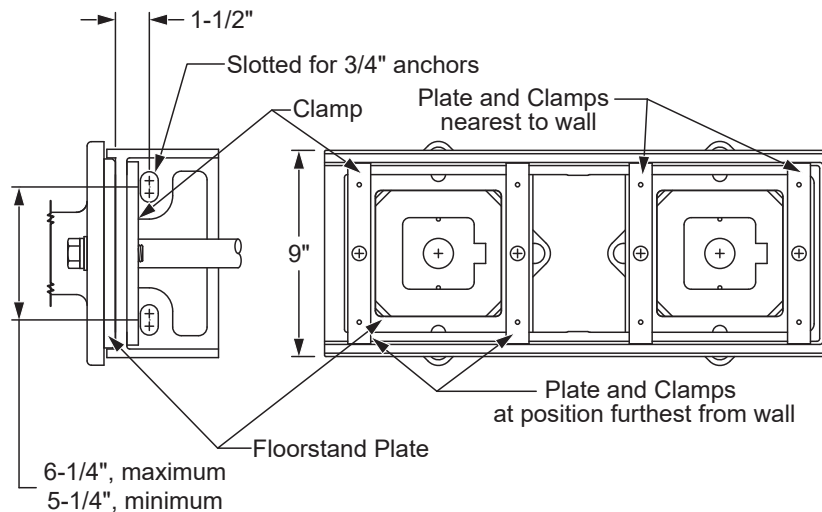
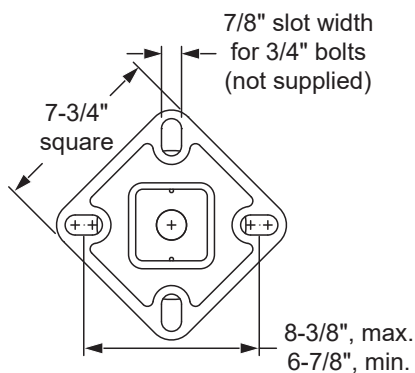
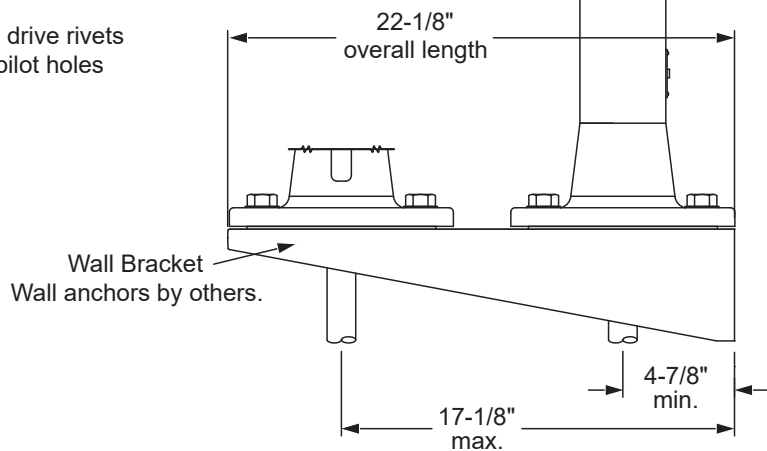

The Floorstand and Handwheel are ductile iron and coated with red primer.
The Wall Bracket is ductile iron; coating is Tnemec 140-1211, NSF61 compliant.

Indicating Floorstand
30" Ductile Iron
Drawn to Scale

Drawn:
FCN
05/20/08

Revision:
FCN
E 01/03/11

Trumbull Manufacturing
Youngstown, Ohio
www.trumbull-mfg.com