

### Installation of Floorstand on Wall Bracket

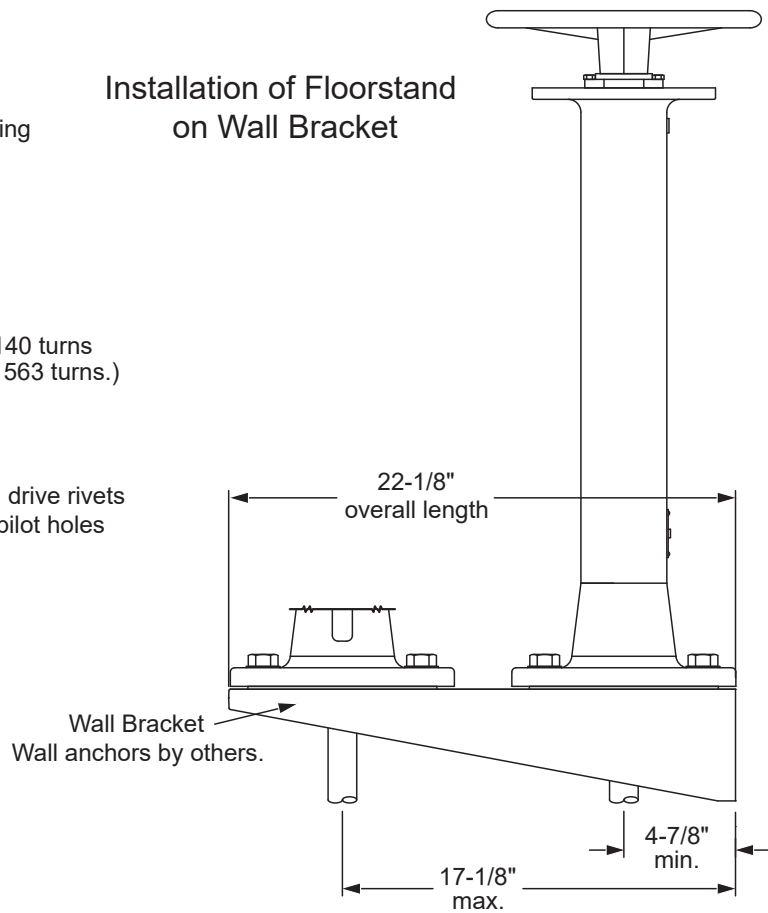

Coupling, grey iron, supplied  
with plated steel spring pins

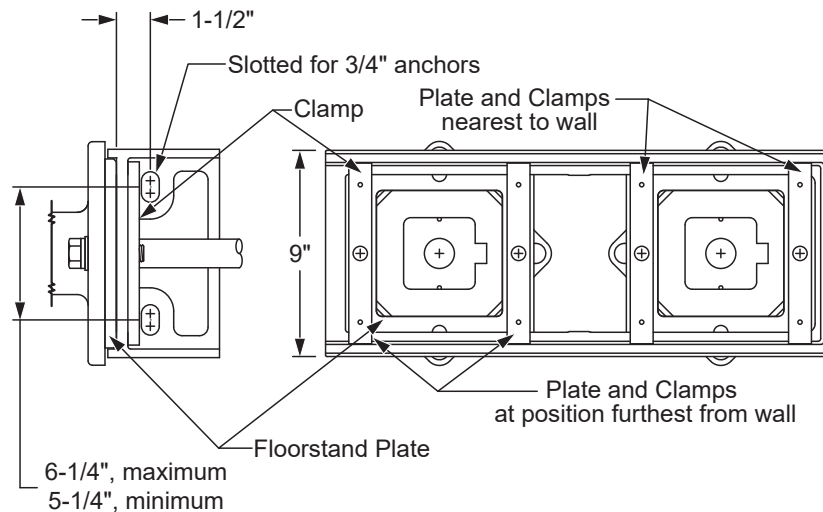
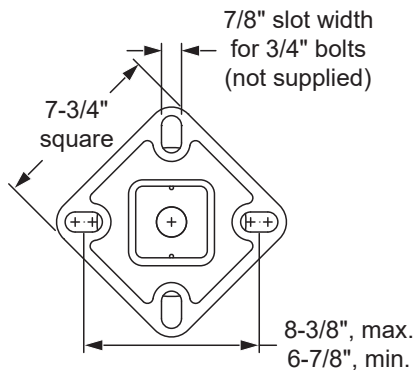

The Floorstand and Handwheel are ductile iron and coated with red primer.  
The Wall Bracket is ductile iron; coating is Tnemec 140-1211, NSF61 compliant.

## Indicating Floorstand 30" Ductile Iron Drawn to Scale

Drawn:  
FCN  
05/20/08

Revision:  
FCN  
E 01/03/11

**Trumbull Manufacturing**  
Youngstown, Ohio  
www.trumbull-mfg.com