

36" Ductile Iron Indicating Floorstand

Includes a Sealed Indicator Slot

Trumbull 36" Ductile Iron Indicating Floorstands are designed for installation in treatment plants and pump stations to allow operation of valves at a lower elevation. Set screw secures handwheel to stem. Flange can be machined to facilitate mounting of actuator, if required (also available with gear operators). Stocked for "open left" valves; also available for "open right" valves. Standard stem threading allows up to 196 turns; optional threading allows up to 784 turns. Stainless drive pin supplied with assembly. Also available in cast stainless steel (page G-51 & G-52). See page G-34 for custom Floorstand options.

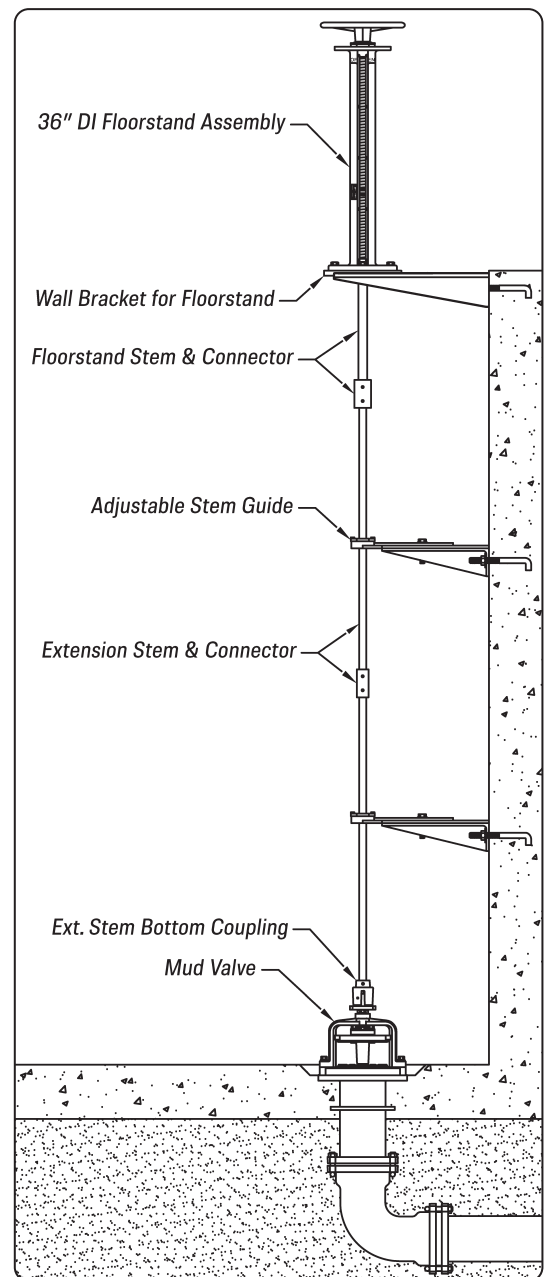
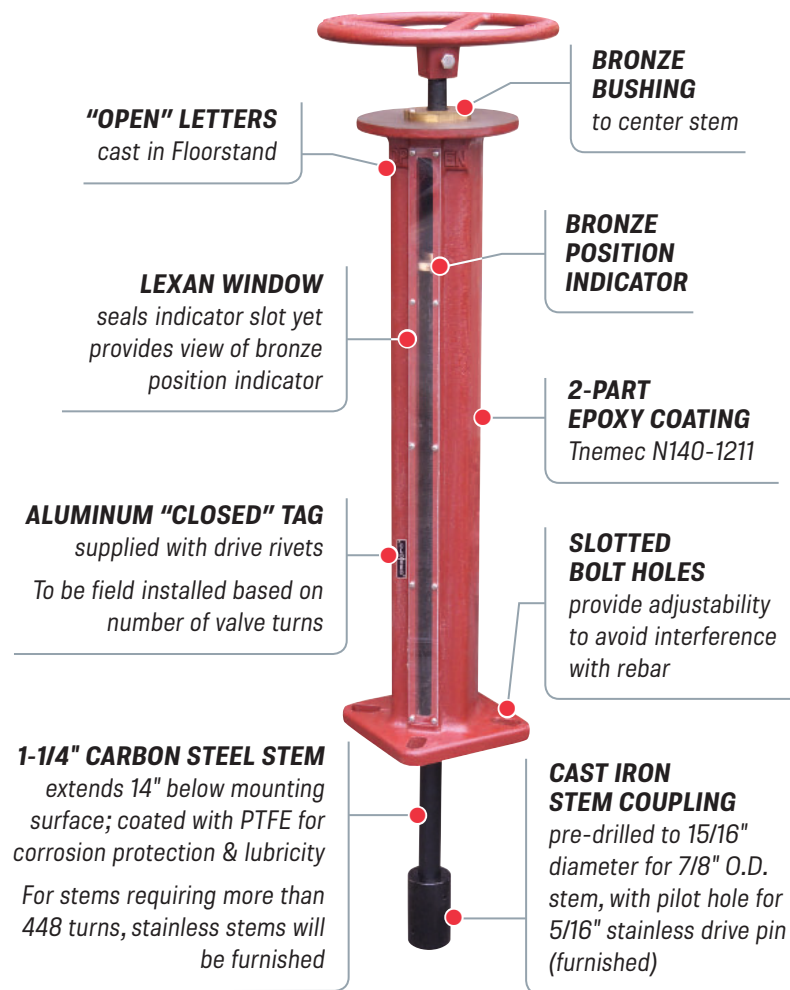

Typical Floorstand installation

Ordering Instructions

1. Quantity required
2. Floorstand item number: **367-2421**
3. O.D. of extension stem being used, for drilling of connecting couplings
4. Wall Bracket, if required
 - a. Ductile iron item number: **367-2451**
 - b. Stainless steel item number: **367-2461**

Installation of Floorstand on Wall Bracket

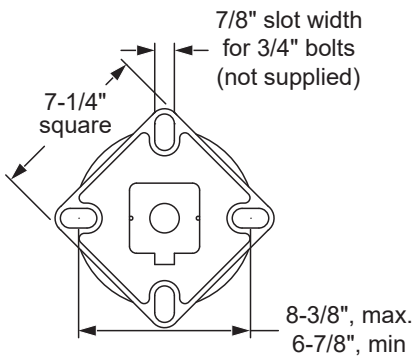
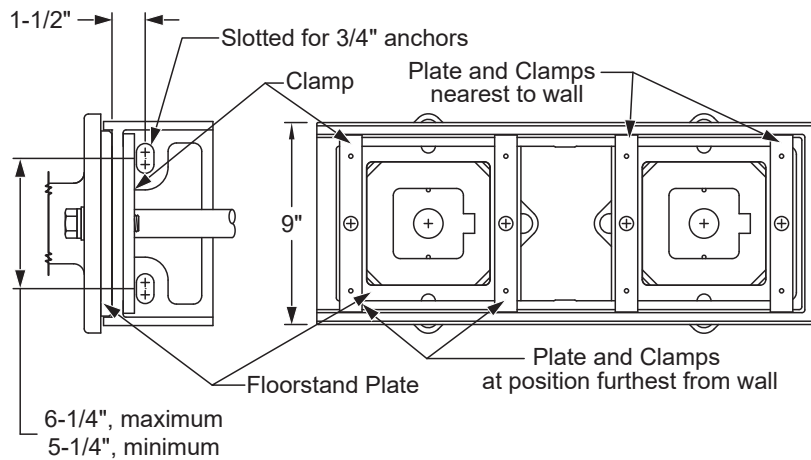
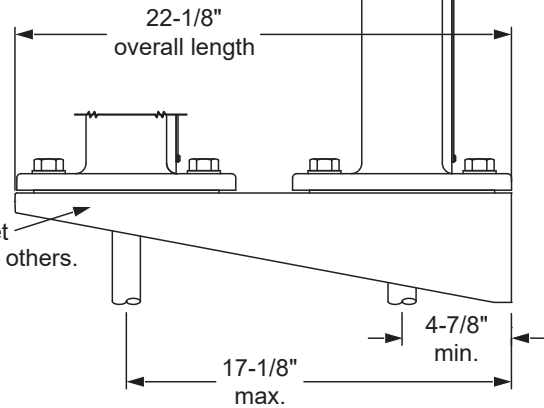
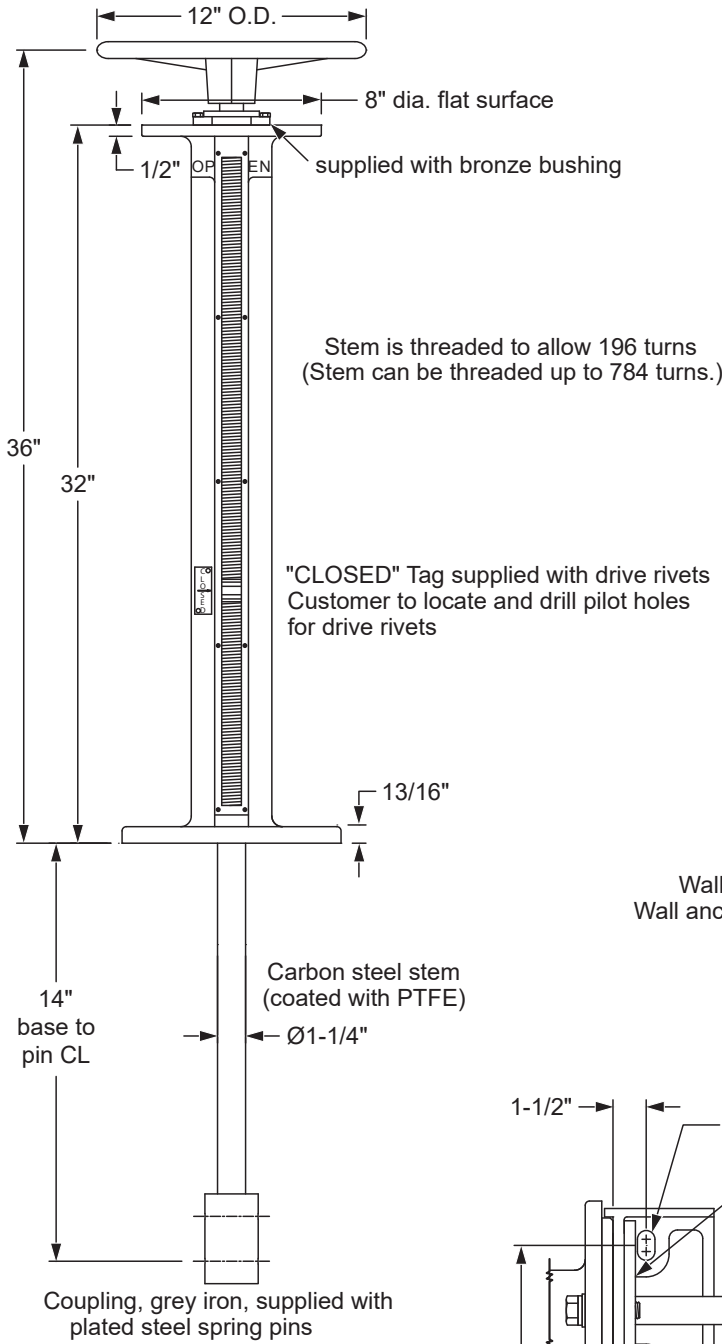

The Floorstand and Handwheel are ductile iron and coated with red primer. The Wall Bracket is ductile iron; coating is TNEMEC 140-1211, NSF61 compliant. Also available in Cast T316 Stainless Steel.

Indicating Floorstand
36" Ductile Iron
Drawn to Scale

Drawn:
FCN
05/20/08

Revision:
FCN
G 11/11/12

Trumbull Manufacturing
Youngstown, Ohio
www.trumbull-mfg.com