

Installation of Floorstand on Wall Bracket

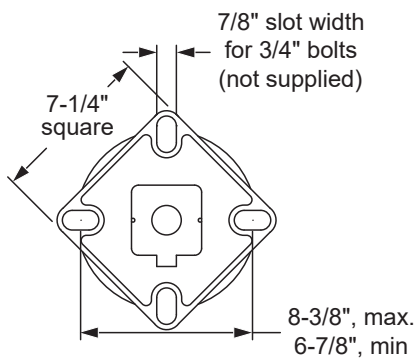
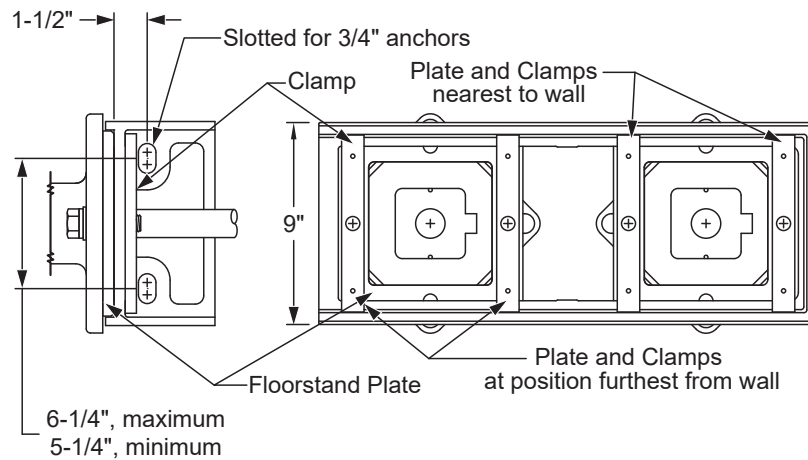
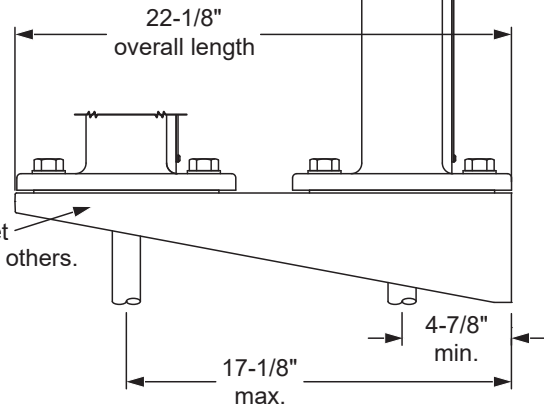
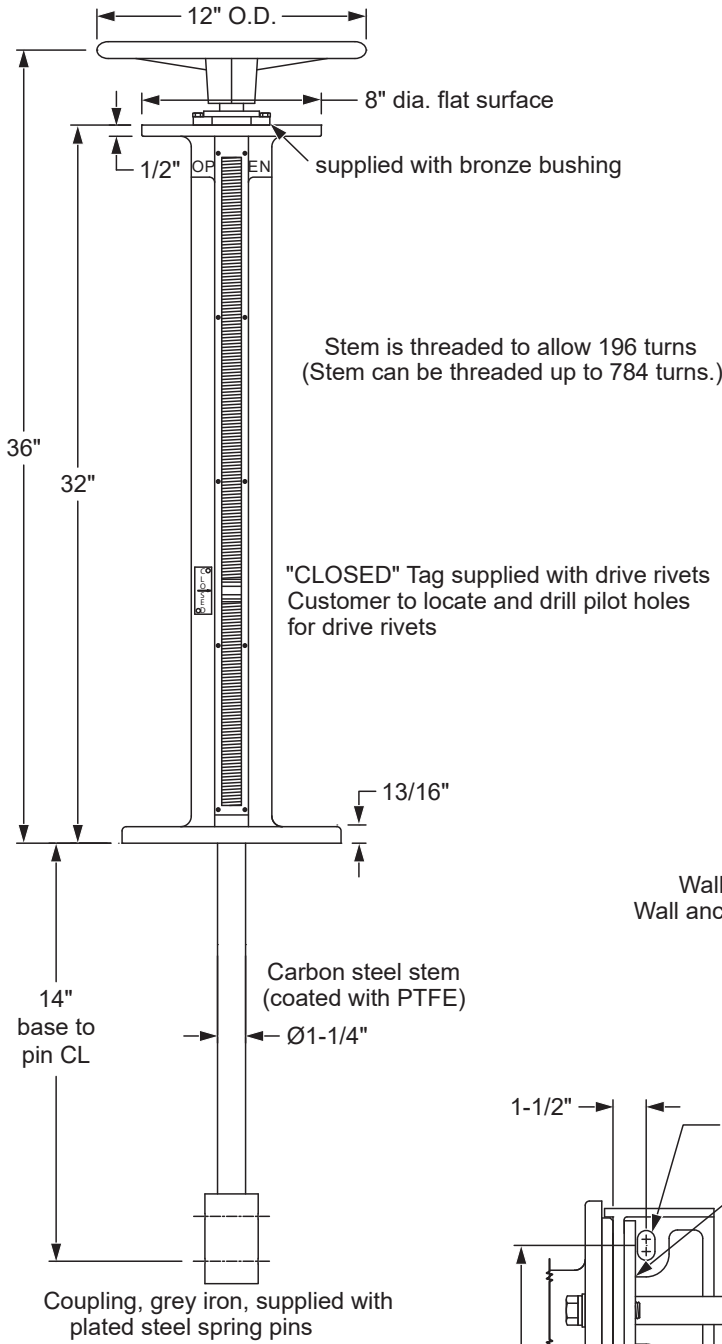

The Floorstand and Handwheel are ductile iron and coated with red primer. The Wall Bracket is ductile iron; coating is TNEMEC 140-1211, NSF61 compliant. Also available in Cast T316 Stainless Steel.

Indicating Floorstand
36" Ductile Iron
Drawn to Scale

Drawn:
FCN
05/20/08

Revision:
FCN
G 11/11/12

Trumbull Manufacturing
Youngstown, Ohio
www.trumbull-mfg.com