

Installation of Floorstand on Wall Bracket

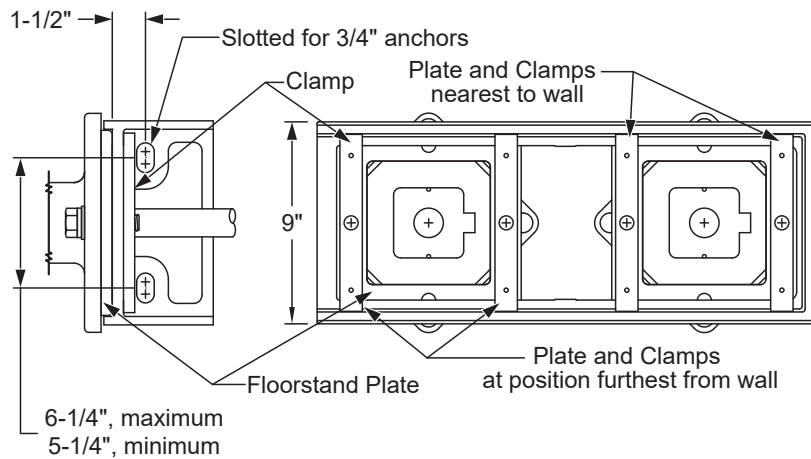
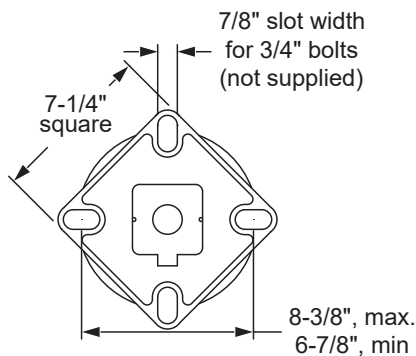
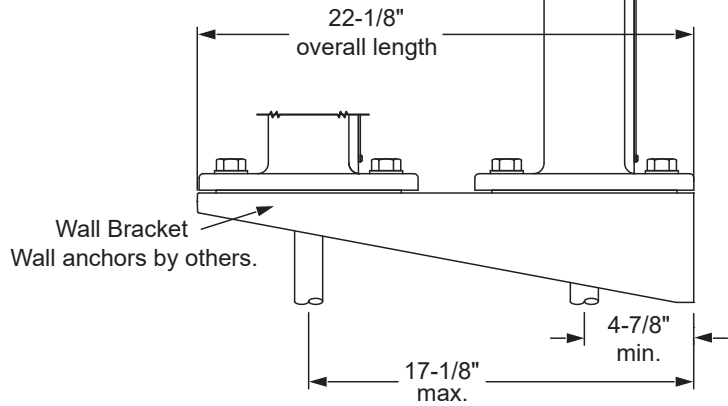

The Floorstand, Handwheel and Wall Bracket are T316 Stainless Steel castings.

Indicating Floorstand
36" Stainless Steel
Drawn to Scale

Drawn:
FCN
05/20/08

Revision:
FCN
G 11/11/12

Trumbull Manufacturing
Youngstown, Ohio
www.trumbull-mfg.com