

Adjustable Stem Guides

Available in Ductile Iron and Stainless Steel

Trumbull Stem Guides are designed for installation in treatment plants and pump stations to provide support for valve extension stems. These Stem Guides are adjustable for stems as close to the wall as 2", or as far away as either 26", 36" or 48".

All ductile iron castings coated with Tnemec N140-1211 epoxy (complies with NSF 61). See reverse side for drawing.

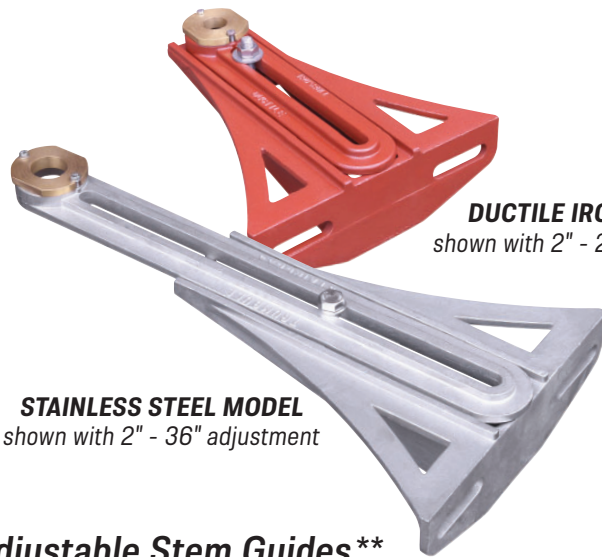

DUCTILE IRON MODEL
shown with 2" - 26" adjustment

STAINLESS STEEL MODEL
shown with 2" - 36" adjustment

Adjustable Stem Guides**

Adjustment Range	Ductile Iron		316 Stainless Steel	
	Domestic Item No	Non-Domestic Item No	Domestic Item No	Non-Domestic Item No
2" to 26"	1367-4960	367-4960	1367-5960	367-5960
2" to 36"	1367-4970	367-4970	1367-5970	367-5970
36" to 48"	1367-4974*	367-4974*	1367-5974*	367-5974*

* Adjustable arm for 36" to 48" range will be fabricated. Stem Guides for stems up to 72" away from wall can be fabricated from either carbon steel or stainless steel, please inquire.

** For product weights, see drawing on Page G-20.

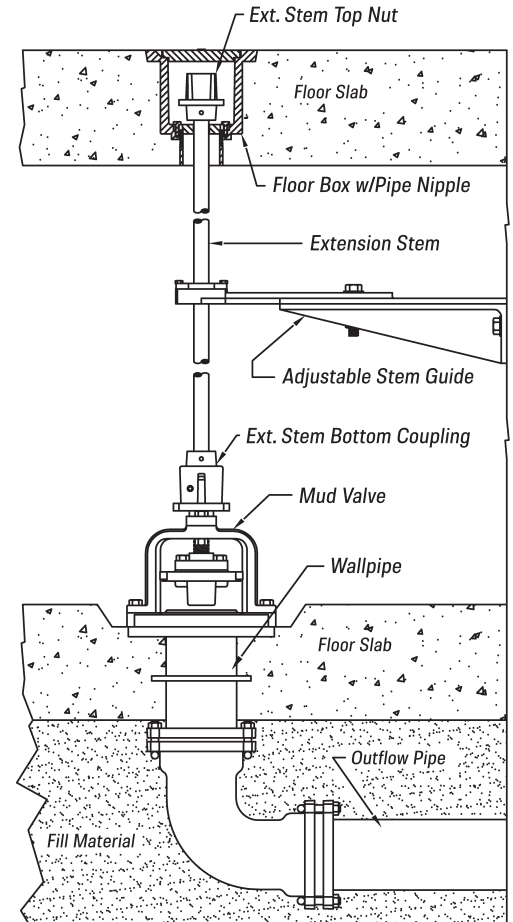

Typical Stem Guide installation

i Stem Guides are generally recommended at 6' to 8' intervals. Bronze bushings can be drilled up to a 2-1/8" bore diameter for 2" O.D. stems. By removing the bushing larger stems can be accommodated, up to 2-3/8" O.D. See pages G-21 - G-24 for Stem Guides for larger diameter stems.

Ordering Instructions

1. Quantity required
2. Provide the Trumbull item number for the model you require (shown above)
3. O.D. of stem being used, or desired bushing material (see note on right) & hole size

Bushings are available in:

- Low-lead brass
- Ultra High Molecular Weight Polyethylene (UHMWPE)
- NSF 61 approved polymer (Ryton® R-4)

Item	Part	Material
1	Base	Ductile Iron or Stainless Steel
2	Arm	Ductile Iron (carbon steel for 36" to 48" version) or Stainless Steel
3	Clamp	Ductile Iron or Stainless Steel
4	Bushing	Low-Lead Brass
5	Bolt	5/8" x 4", Hex Head, Stainless Steel
6	Washer	1-1/2" O.D., Stainless Steel
7	Nut	5/8", Hex, Stainless Steel
8	Screw	1/4"-20 UNC, Stainless Steel

Item No.	Size	Weight
Ductile Iron Guides (65-45-12)		
367-4960	2" - 26"	25 lbs.
367-4970	2" - 36"	28 lbs.
367-4974	36" - 48"	38 lbs.
Stainless Steel Guides (T316)		
367-5960	2" - 26"	25 lbs.
367-5970	2" - 36"	29 lbs.
367-5974	36" - 48"	37 lbs.

All Ductile Iron and carbon steel components are coated with Tnemec N140-1211, NSF 61 compliant.

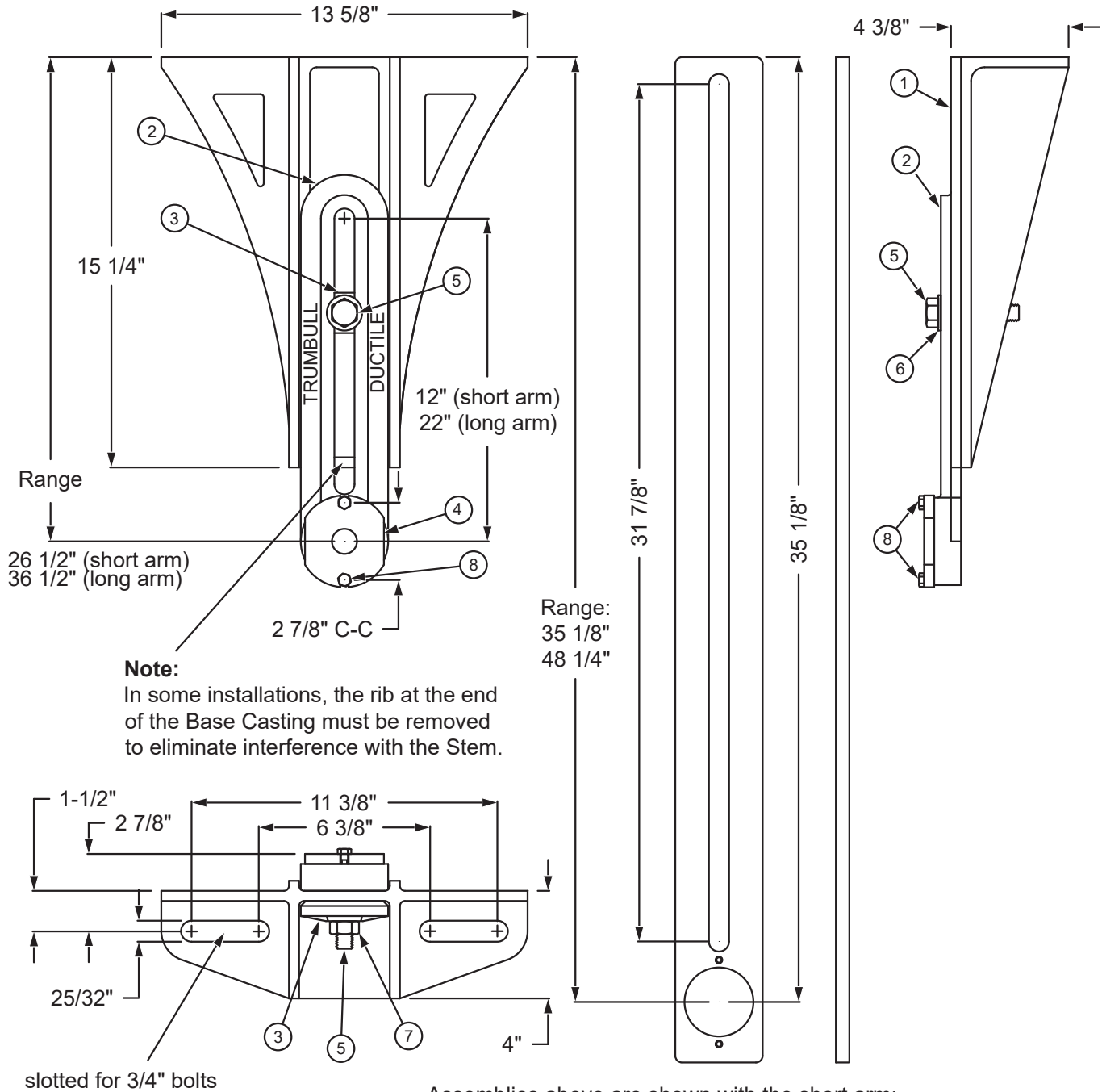

Note:
In some installations, the rib at the end of the Base Casting must be removed to eliminate interference with the Stem.

Assemblies above are shown with the short arm;
use the separate arm shown above to make the 36" to 48" stem guide.

ADJUSTABLE STEM GUIDES

Drawn to Scale

Drawn:
FCN
04/25/15

Revision:
FCN
 07/24/19

Trumbull Manufacturing
Youngstown, Ohio
www.trumbull-mfg.com