

Item	Part	Material
1	Base	Ductile Iron or Stainless Steel
2	Arm	Ductile Iron (carbon steel for 36" to 48" version) or Stainless Steel
3	Clamp	Ductile Iron or Stainless Steel
4	Bushing	Low-Lead Brass
5	Bolt	5/8" x 4", Hex Head, Stainless Steel
6	Washer	1-1/2" O.D., Stainless Steel
7	Nut	5/8", Hex, Stainless Steel
8	Screw	1/4"-20 UNC, Stainless Steel

Item No.	Size	Weight
Ductile Iron Guides (65-45-12)		
367-4960	2" - 26"	25 lbs.
367-4970	2" - 36"	28 lbs.
367-4974	36" - 48"	38 lbs.
Stainless Steel Guides (T316)		
367-5960	2" - 26"	25 lbs.
367-5970	2" - 36"	29 lbs.
367-5974	36" - 48"	37 lbs.

All Ductile Iron and carbon steel components are coated with Tnemec N140-1211, NSF 61 compliant.

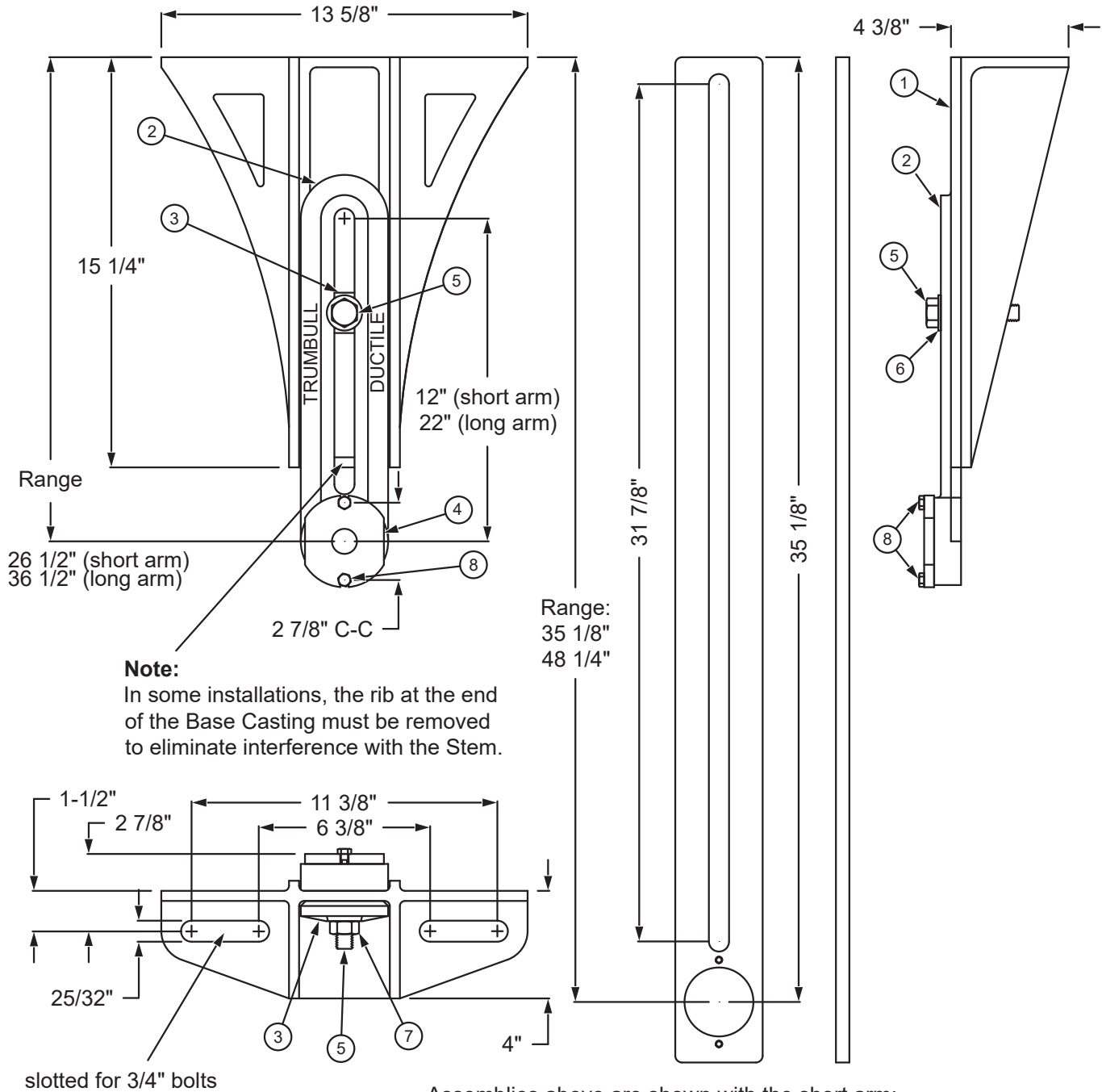

Note:
In some installations, the rib at the end of the Base Casting must be removed to eliminate interference with the Stem.

Assemblies above are shown with the short arm;
use the separate arm shown above to make the 36" to 48" stem guide.

ADJUSTABLE STEM GUIDES

Drawn to Scale

Drawn:
FCN
04/25/15

Revision:
FCN
07/24/19

Trumbull Manufacturing
Youngstown, Ohio
www.trumbull-mfg.com