

Cast Iron Floor Box

Floor Boxes are designed for installation in concrete floors or slabs to provide support for extension stems for non-rising type valves, and to provide a cover over the operating nut on the extension stem.

The Trumbull Cast Iron Floor Box is designed for varying slab thicknesses. Overall length is 6", but the underside is tapped to accept 2-1/2" NPT steel pipe nipples for floors thicker than 6". When it's necessary to use a Floor Box with thicker floors, use a 2-1/2" pipe nipple, 1/2" longer than the increase required, as the threads on the underside of the Floor Box are 1/2" deep (see picture on lower right corner of page G-13). For example, for an 8" floor thickness use a 2-1/2" x 2-1/2" nipple. For a 10" floor, use a 2-1/2" x 4-1/2" nipple.

When a stem is required that is larger than the 2-1/2" pipe I.D., a 3" pipe nipple will be welded to the bottom of the Floor Box.

The Cast Iron Floor Box should be ordered with a removable brass bushing for which the maximum drilling is normally 2-3/8" diameter. For larger diameters, please contact Trumbull. However, when used with floors thicker than 6", clear opening is limited to the I.D. of the pipe nipple. See reverse side for drawing.



Item No	Weight
367-4620	25.65 lbs.

NOT for use with Valve Position Indicators.

See page G-15 for Sealed Floor Boxes for use with the Position Indicators.

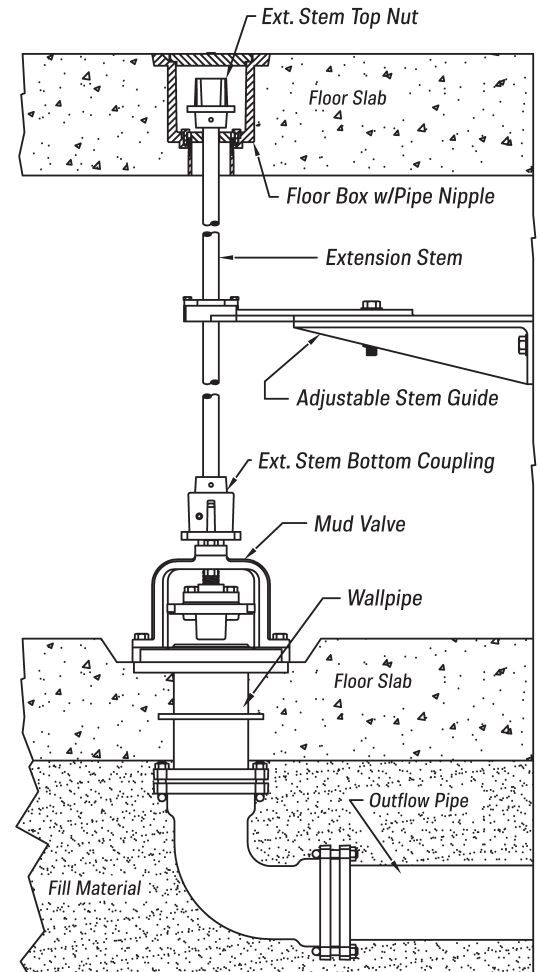

Typical Floor Box installation

Bushings are available in:

- Low-lead brass
- Ultra High Molecular Weight Polyethylene (UHMWPE)
- NSF 61 approved polymer (Ryton® R-4)

Ordering Instructions

1. Quantity required
2. Thickness of floor slab, or length of pipe nipple required
3. O.D. of stem being used, or desired bushing material & hole size
4. Custom options available such as stainless steel construction, O-Ring lids, water-tight seals, tamper-resistant lids & anchoring collar

When Valve Position Indicator is installed in a floor, use the cast iron **HOUSING ADAPTER** illustrated on pages F-1 - F-8, or the **SEALED FLOOR BOXES** shown on pages G-13 - G-16.

Item	Component	Material
1	Body	Cast Iron, A126(B)
2	Lid	Cast Iron, A126(B)
3	Bushing	Low-Lead Brass
4	Screw, Hex Head	Stainless Steel, Type 316

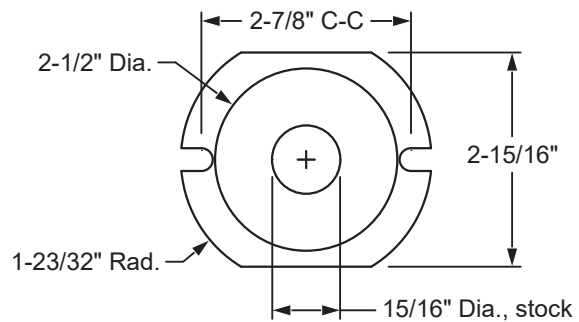
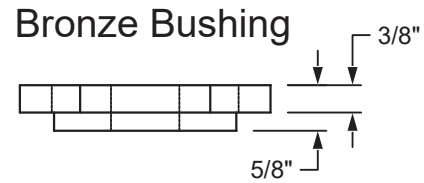
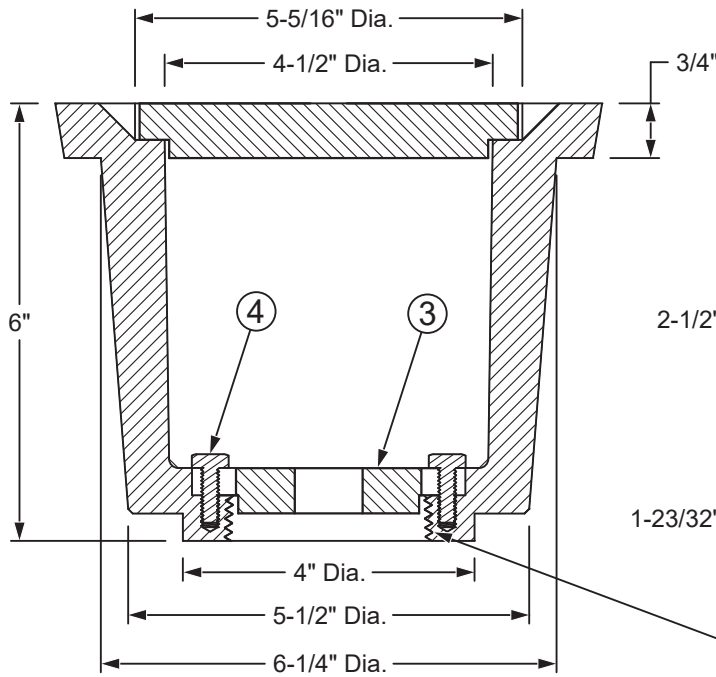
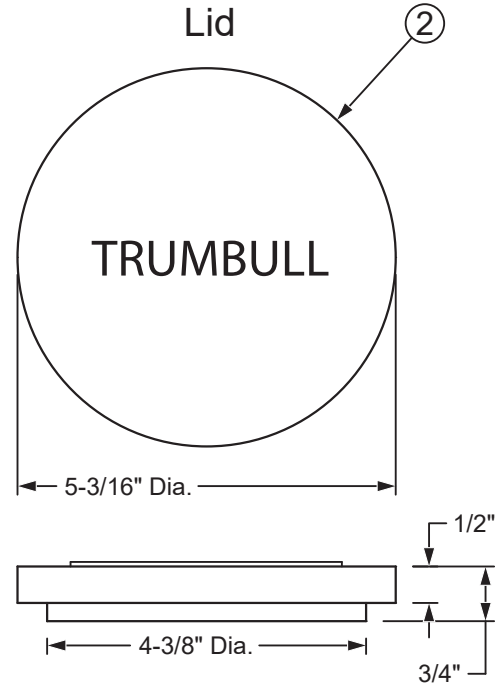
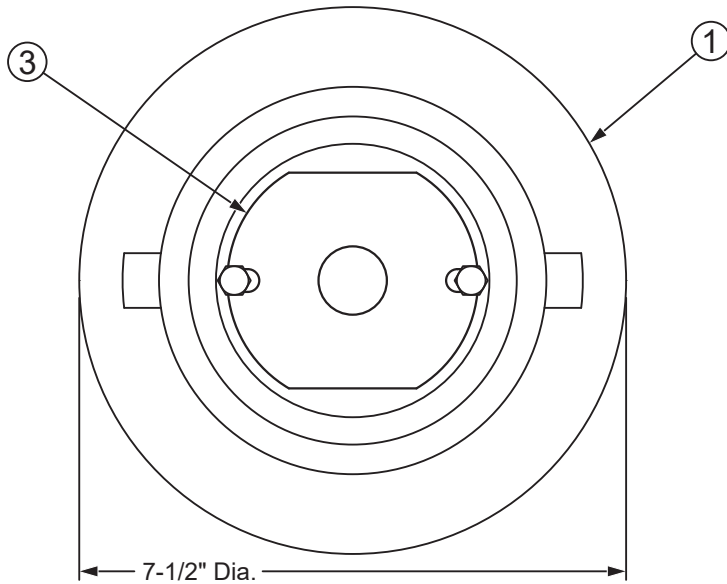

The bottom of the Floor Box casting is tapped with a 2-1/2" NPT thread.

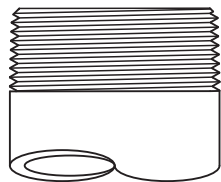

Use a pipe nipple 1/2" longer than the increase in floor slab thickness required, as the tapped thread is 1/2" deep.

Coated all over with black enamel rust preventative.

CAST IRON FLOOR BOX

Drawn to Scale

Drawn:
FCN
04/04/94

Revision:
FCN
 04/07/15

Trumbull Manufacturing
Youngstown, Ohio
www.trumbull-mfg.com