

Item	Component	Material
1	Body	Cast Iron, A126(B)
2	Lid	Cast Iron, A126(B)
3	Bushing	Low-Lead Brass
4	Screw, Hex Head	Stainless Steel, Type 316

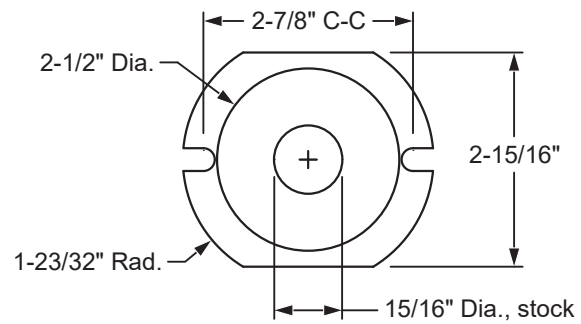

The bottom of the Floor Box casting is tapped with a 2-1/2" NPT thread.

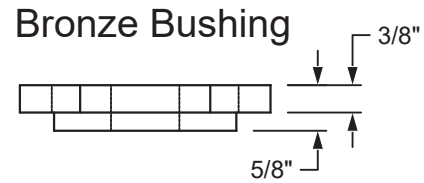
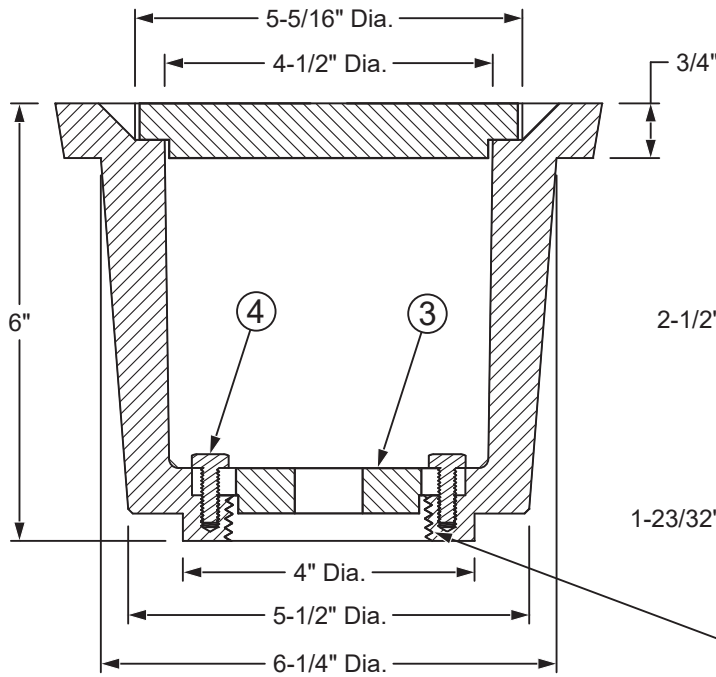
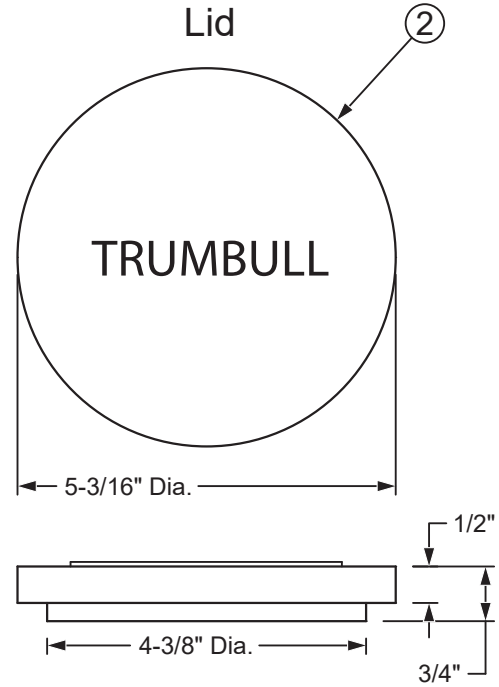
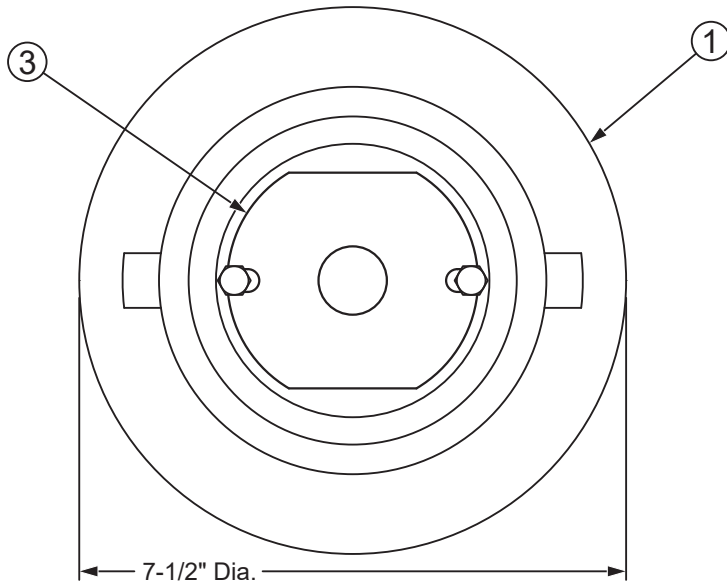
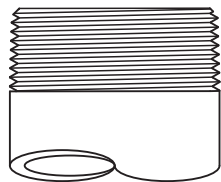

Use a pipe nipple 1/2" longer than the increase in floor slab thickness required, as the tapped thread is 1/2" deep.

Coated all over with black enamel rust preventative.

CAST IRON FLOOR BOX

Drawn to Scale

Drawn:
FCN
04/04/94

Revision:
FCN
 04/07/15

Trumbull Manufacturing
Youngstown, Ohio
www.trumbull-mfg.com