

## Cast Iron Meter Yokes

Trumbull Meter Yokes provide uniform spacing and alignment for setting water meters. Used in conjunction with Expansion Connections for easy installation and removal of meters.

Cast of gray iron, Class 25, with rust-preventative black coating.

Item No	Meter Size	Length	Height	Weight
<b>367-5470</b>	5/8"	10-15/16"	4-1/8"	3.65 lbs.
<b>367-5469</b>	5/8" x 3/4"	10-15/16"	4-1/8"	4.20 lbs.
<b>367-5471</b>	3/4"	12-1/2"	4-1/8"	4.60 lbs.
<b>367-5472</b>	1"	14-3/4"	5-1/4"	7.30 lbs.

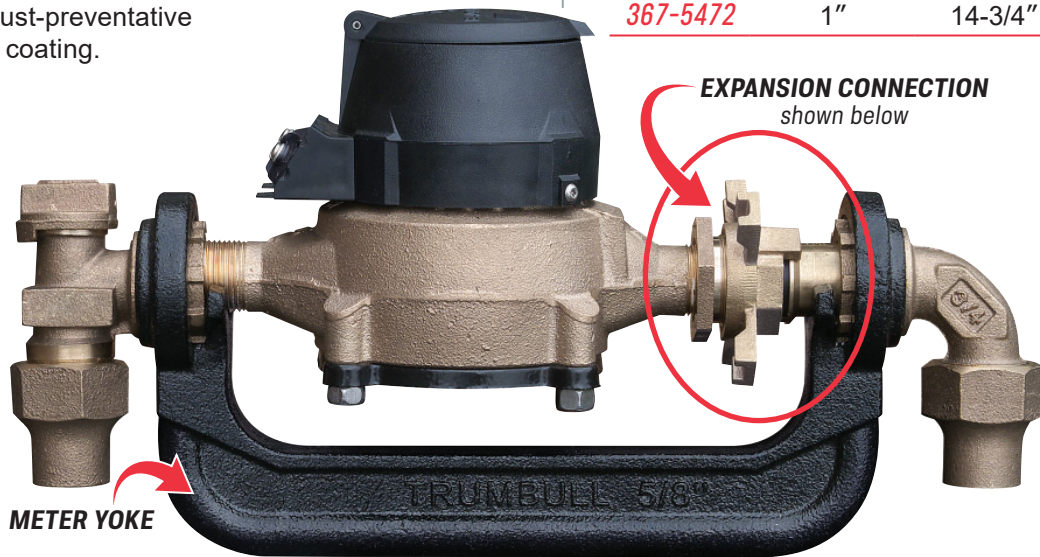

## Expansion Connections

Expansion Connections are screwed onto one end of a meter and allow for easy installation and removal from Meter Yoke. Turning the Handwheel causes expansion into the rubber gaskets in the Yoke, creating a water-tight seal.

Nose Piece and Barrel are in contact with water and are cast from UNS C89833 brass. Certified by UL for compliance with NSF/ANSI 61 and NSF/ANSI 372, per the U.S. Safe Drinking Water Act.

Handwheel does not contact water and is cast from UNS C83600. Both the flat seal yoke gaskets and bevelled seal gasket are EPDM. Expansion seal gasket between barrel and meter is fiber; however, for polymer meters with pressed on metal threads, a soft rubber gasket is required. Please specify on order. All gaskets are NSF-61.

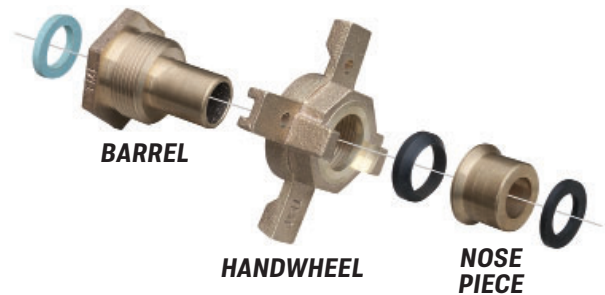

*Dimensions of Yokes & Expansion Connections are consistent & interchangeable with other industry manufacturers.*

Item No	Meter Size	Size	Type	Weight
<b>368-0630</b>	5/8"	5/8"	Handwheel	0.72 lbs.
<b>368-0632</b>	5/8" x 3/4" & 3/4"	3/4"	Handwheel	0.93 lbs.
<b>368-0635</b>	1"	1"	Handwheel	1.61 lbs.

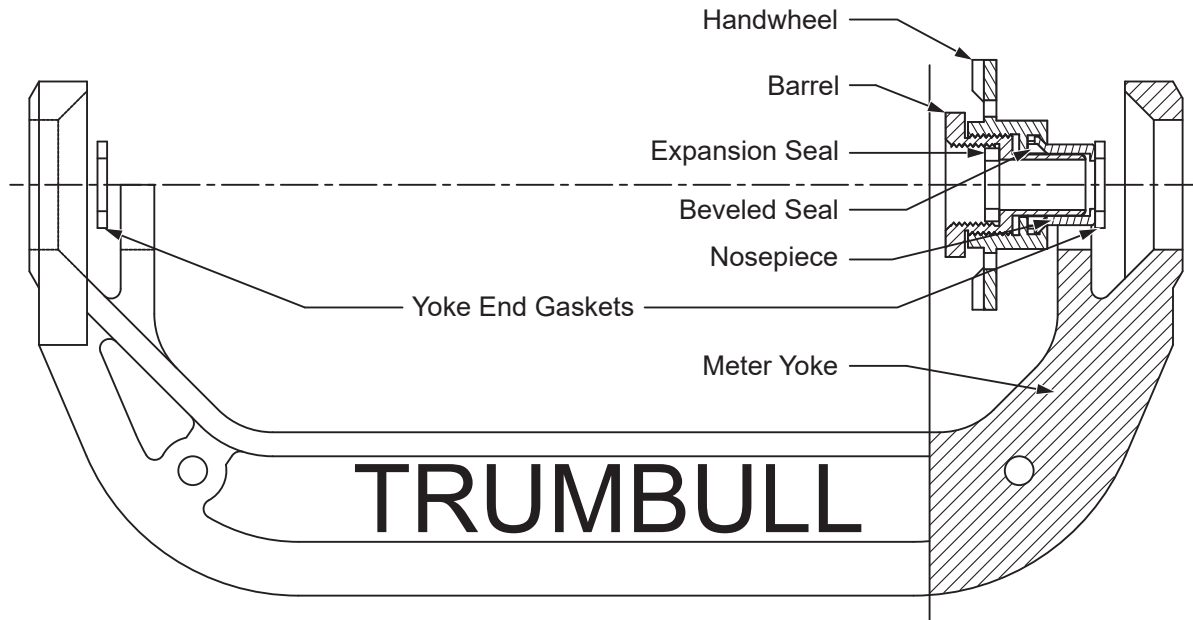

Barrel and Nosepiece are in contact with potable water and will conform to UNS C89833. They will be marked, "NL", and are certified by UL for compliance with NSF/ANSI 61 and NSF/ANSI 372, per the U.S. Safe Drinking Water Act. EPDM and fiber seals meet NSF/ANSI 61.

Handwheel is not in contact with potable water and will conform to UNS C83600.

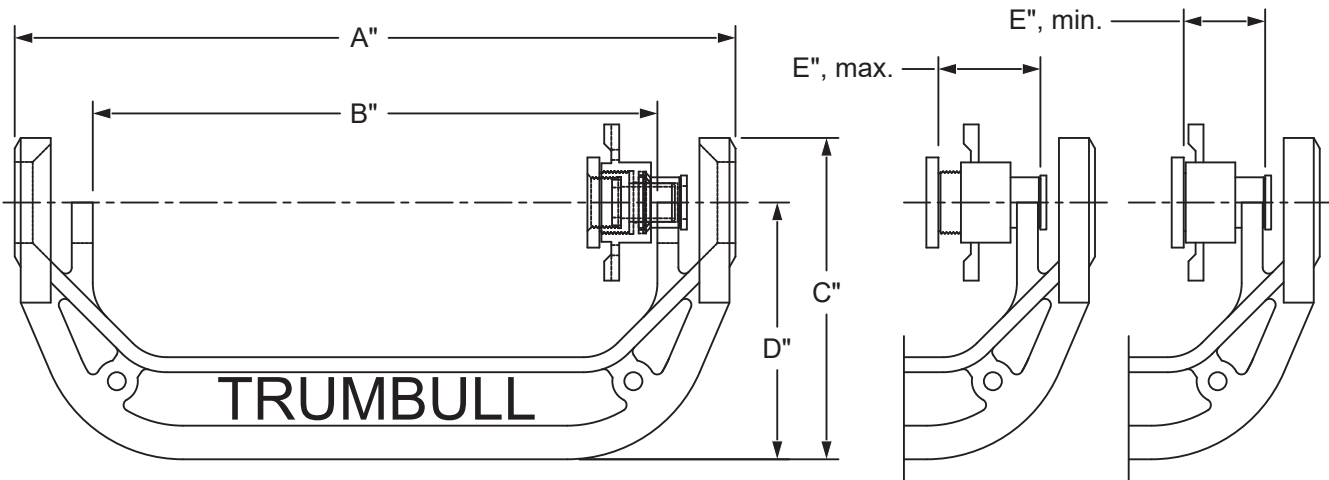

Meter Size	Yoke						Expander			
	A"	B"	C"	D"	Wt., lbs.	Item No.	Bore Size	E", min.- max.	Wt., lbs.	Item No.
5/8"	10.69"	8.19"	5.16"	3.88"	3.9	367-5470	0.59"	1.44" - 1.75"	0.65	368-0630
5/8" x 3/4"	10.94"	8.34"	5.16"	3.88"	4.1	367-5469	0.72"	1.75" - 2.0"	0.85	368-0632
3/4"	12.31"	9.81"	5.16"	3.88"	4.4	367-5471	0.72"	1.75" - 2.0"	0.85	368-0632
1"	14.88"	11.75"	6.69"	5.34"	7.25	367-5472	0.97"	2.19" - 2.63"	1.65	368-0635

Material:  
ASTM Class 30 Gray Iron,  
black E-coat all surfaces.

UNS C89833 - Barrel and Nosepiece certified by UL for compliance with NSF/ANSI 61 and NSF/ANSI 372, per the U.S. Safe Drinking Water Act. (In contact with potable water).

**METER YOKE and  
EXPANSION CONNECTIONS**  
Drawn to Scale

Drawn:  
FCN  
05/19/14

Revision:  
FCN  
© 04/07/15

**Trumbull Manufacturing**  
Youngstown, Ohio  
www.trumbull-mfg.com