

Barrel and Nosepiece are in contact with potable water and will conform to UNS C89833. They will be marked, "NL", and are certified by UL for compliance with NSF/ANSI 61 and NSF/ANSI 372, per the U.S. Safe Drinking Water Act. EPDM and fiber seals meet NSF/ANSI 61.

Handwheel is not in contact with potable water and will conform to UNS C83600.

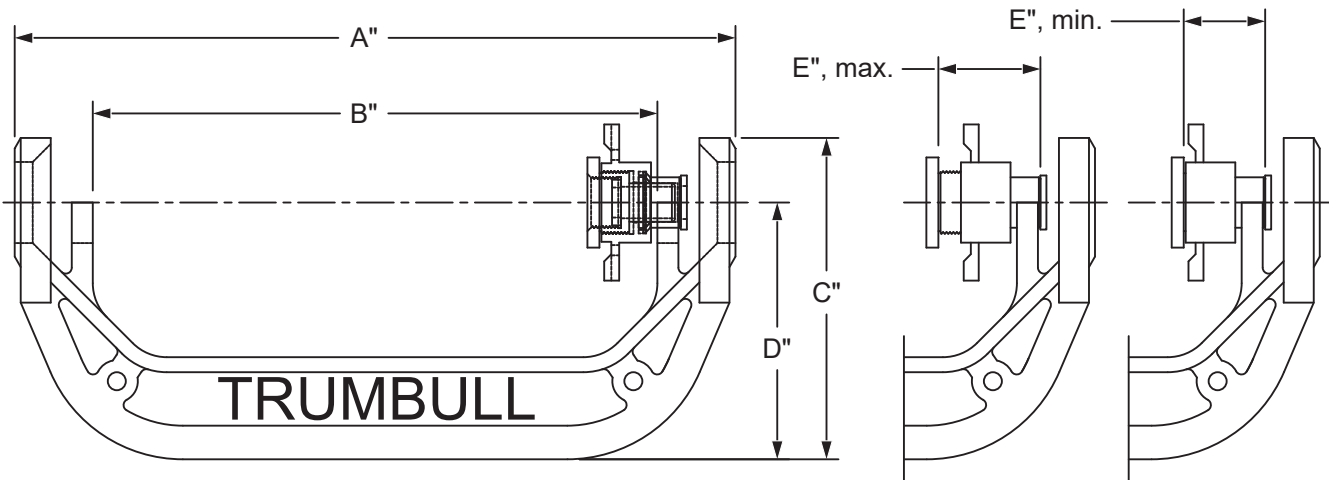

| Meter Size | Yoke | | | | | | Expander | | | |
|-------------|--------|--------|-------|-------|-----------|----------|-----------|----------------|-----------|----------|
| | A" | B" | C" | D" | Wt., lbs. | Item No. | Bore Size | E", min.- max. | Wt., lbs. | Item No. |
| 5/8" | 10.69" | 8.19" | 5.16" | 3.88" | 3.9 | 367-5470 | 0.59" | 1.44" - 1.75" | 0.65 | 368-0630 |
| 5/8" x 3/4" | 10.94" | 8.34" | 5.16" | 3.88" | 4.1 | 367-5469 | 0.72" | 1.75" - 2.0" | 0.85 | 368-0632 |
| 3/4" | 12.31" | 9.81" | 5.16" | 3.88" | 4.4 | 367-5471 | 0.72" | 1.75" - 2.0" | 0.85 | 368-0632 |
| 1" | 14.88" | 11.75" | 6.69" | 5.34" | 7.25 | 367-5472 | 0.97" | 2.19" - 2.63" | 1.65 | 368-0635 |

Material:
ASTM Class 30 Gray Iron,
black E-coat all surfaces.

UNS C89833 - Barrel and Nosepiece certified by UL for compliance with NSF/ANSI 61 and NSF/ANSI 372, per the U.S. Safe Drinking Water Act. (In contact with potable water).

**METER YOKE and
EXPANSION CONNECTIONS**
Drawn to Scale

Drawn:
FCN
05/19/14

Revision:
FCN
© 04/07/15

Trumbull Manufacturing
Youngstown, Ohio
www.trumbull-mfg.com