

## Telescoping Valves

Trumbull Telescoping Valves are designed to regulate the level of fluids in containment structures such as holding chambers, tanks, ponds & lagoons. An example of an application might be to regulate the effluent level in a settling basin. Also known as “Sludge Draw-off Valves” or “Decanting Valves”, the valve assembly consists of a lifting mechanism (operator), connecting stem and a slip (drain) tube which travels vertically inside a fixed vertical pipe. Utilizing the operator, the slip tube is raised or lowered to maintain the desired fluid level within the containment structure.

Trumbull offers Telescoping Valves in either Rising or Non-Rising Stem designs. A variety of operators are available such as, handwheel, rack & pinion, bevel gear and electric motor operators. The slip tubes are available in a variety of sizes and materials, the most common materials being 304 stainless steel and Sch 40 PVC. Other materials are available upon application or request. Slip tubes are typically supplied with V-notch, plain end or funnel tops. Scum baffles can also be added to the top of the slip tube, if requested.

Trumbull’s seal assembly consists of a stainless steel retainer plate, a seal plate and two (2) Buna-N wiper gaskets. The assembly is designed so that the wiper gaskets can easily be replaced in the field without disassembling the Telescoping Valve. Additional seal elastomers available upon request.

Operator pedestals are available in 26” & 32” cast ductile iron Indicating Style, 32” cast ductile iron Non-Indicating Style and 32” cast stainless steel Indicating Style. Other custom-fabricated styles and materials are available upon request. Offset wall brackets are available in either cast ductile iron or cast 316 stainless steel.

Lifting bails are fabricated from 304 stainless steel material, and are mounted to the slip tubes with stainless steel fasteners. Threaded operating stems and extension stems are made from 304 stainless steel material unless otherwise specified.

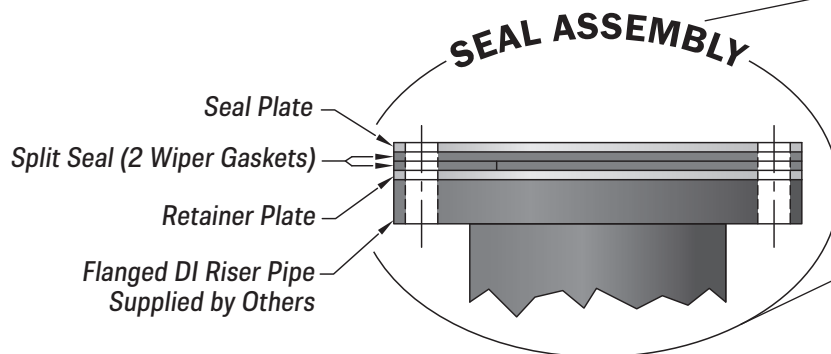

*The above information requirements are available in drawing form on the following pages.*

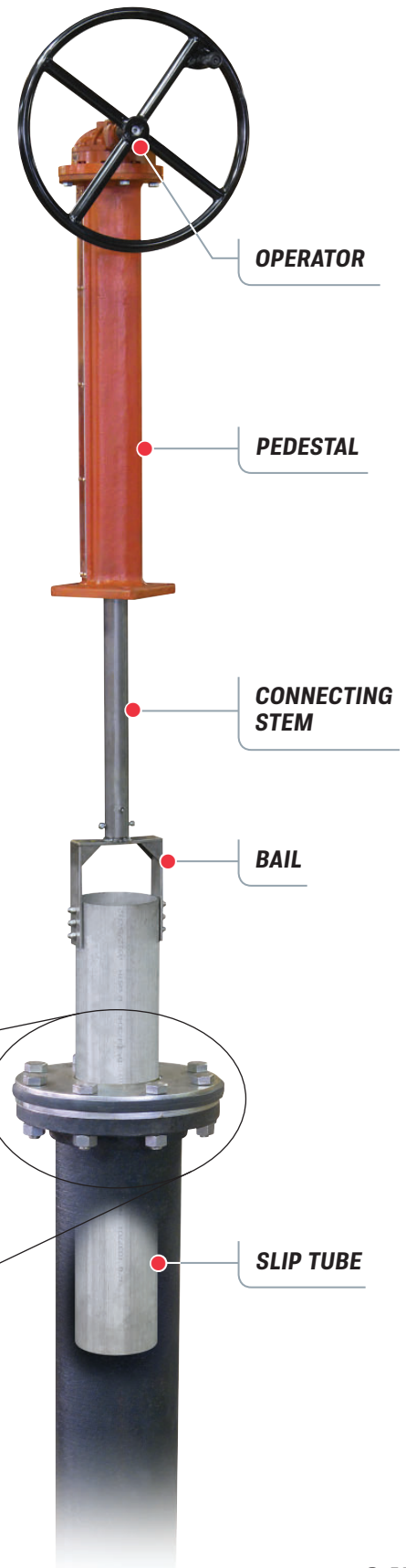

MK-#	Description	Qty/Assem.	Std. Mat'l
1	Clear Stem Cover	Varies	PVC
2	Operator, Bevel Gear (See Options)	1 Piece	Carbon Stl.
3	Floorstand Non-Indicating 32"	1 Piece	Ductile Iron
4	Adjustable Wall Mount Brkt 17-1/8" Max.	1 Piece	Ductile Iron
5	Travel Rack 3/4" Dia	Varies	303 SS
6	Rack Coupling Round	1 Piece	304 SS
7	Stem Extension Solid Rod	Varies	304 SS
8	Lifting Bail	1 Piece	304 SS
9	Scum Baffle (See Options)	1 Piece	304 SS
10	Slip Tube (See Options)	Varies	304 SS
11	Seal Plate 125# Drilling, 3/8" Thk	1 Piece	304 SS
12	Seal 125# Drilling, 1/4" Thk, Dove Tailed	2 Pieces	Buna-N
13	Retainer Plate 125# Drilling, 1/4" Thk	1 Piece	304 SS

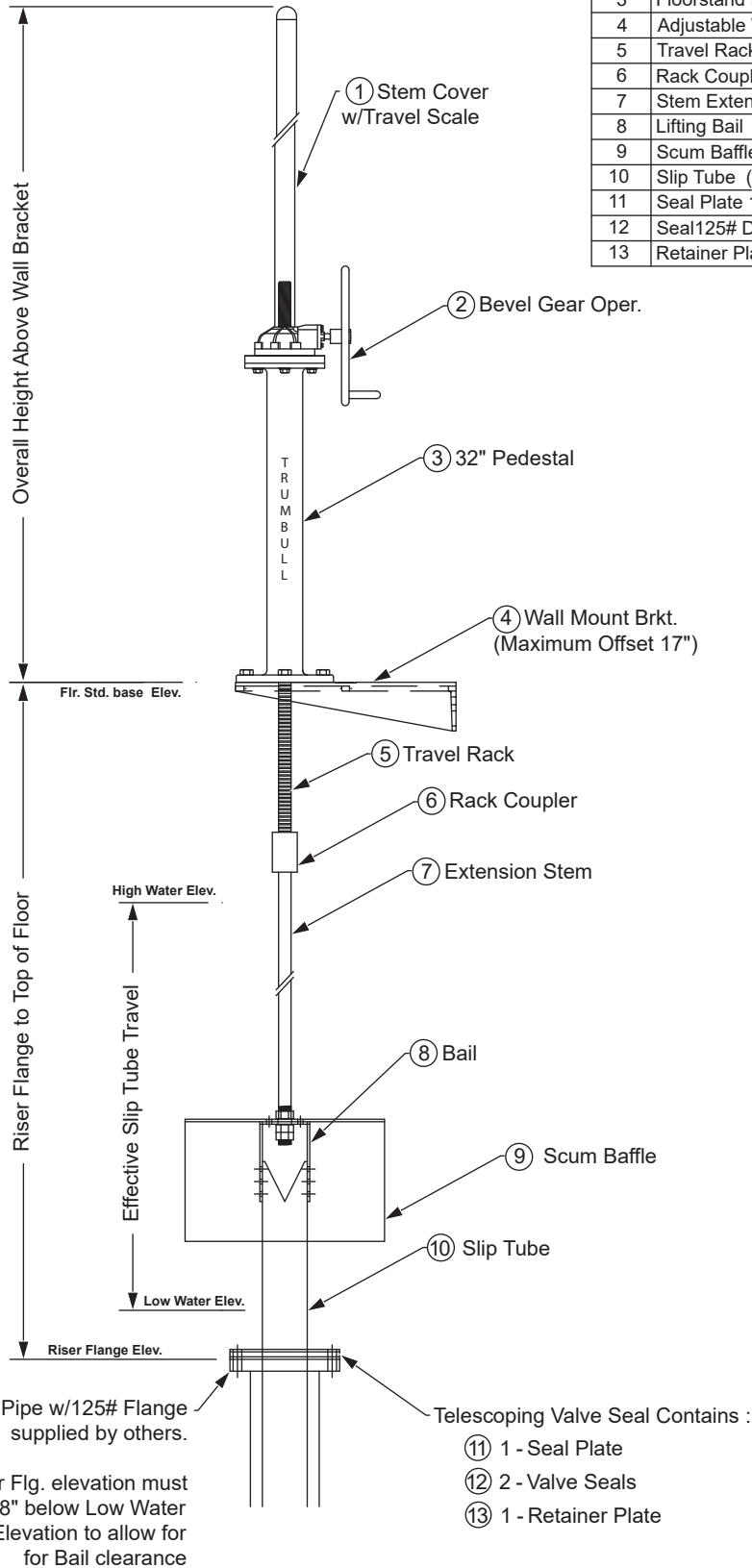

**Telescoping Valve Options**

**Operators:**

Handwheel Rising Stem \_\_\_\_\_

Handwheel Non-Rising Stem \_\_\_\_\_

Bevel Gear Rising Stem \_\_\_\_\_

Bevel Gear Non-Rising Stem \_\_\_\_\_

Electric Motor Actuator \_\_\_\_\_

**Scum Baffle:**

20" Dia. x 12" Tall x .062" Thk \_\_\_\_\_

Other Sizes- Dia. - \_\_\_\_\_

Height - \_\_\_\_\_

Thickness - \_\_\_\_\_

**Slip Tube Options:**

**Material:**

304SS \_\_\_\_\_

316SS \_\_\_\_\_

PVC S40 \_\_\_\_\_

**Tube Top Configurations:**

Plain End \_\_\_\_\_

"V" Notch \_\_\_\_\_

12" Dia. Funnel \_\_\_\_\_

Other (Describe Below) \_\_\_\_\_

\_\_\_\_\_

\_\_\_\_\_

**Wall Mount Bracket Material:**

Ductile Iron \_\_\_\_\_

Stainless Steel \_\_\_\_\_

Not Required \_\_\_\_\_

**Customer Provided Dimensions**

Valve Size : \_\_\_\_\_

**Elevations:**

Floor Stand Base Elevation \_\_\_\_\_

High Water Elevation \_\_\_\_\_

Low Water Elevation \_\_\_\_\_

Riser Flange Elevation \_\_\_\_\_

**Customer Provided Project Info.**

Project Name: \_\_\_\_\_

Project City: \_\_\_\_\_

Project State: \_\_\_\_\_

Qty. Req'd: \_\_\_\_\_

**Customer Information**

Customer: \_\_\_\_\_

Branch: \_\_\_\_\_

Contact Name: \_\_\_\_\_

Phone: \_\_\_\_\_

Email: \_\_\_\_\_

Reference #: \_\_\_\_\_

Note: Wall Brkt. anchors & Flg Bolts Supplied by others.  
 Note: Slip Tube & Bail fasteners, supplied by Trumbull will be 304SS

**Telescoping Valve**  
 Drawn to Scale

Drawn: FCN  
 11/20/13

Revision: NJC  
 (B) 01/20/20

**Trumbull Manufacturing**  
 Youngstown, Ohio  
 www.trumbull-mfg.com